

TECHNICAL BULLETIN

POLICY DIRECTIVE GOVERNING THE EXECUTION OF THE JOINT AIRFRAME CONDITION EVALUATION (JACE) IN THE FIELD FOR ARMY AND AIR FORCE ALL H-60 AIRCRAFT

DISTRIBUTION STATEMENT A: Approved for Public Release; Distribution is unlimited.

HEADQUARTERS, DEPARTMENT OF THE ARMY AND AIR FORCE

15 MARCH 1997

CHANGE
NO. 1

HEADQUARTERS
DEPARTMENT OF THE ARMY
WASHINGTON, D. C., 30 August 2002

POLICY DIRECTIVE GOVERNING THE EXECUTION
OF THE JOINT AIRFRAME CONDITION
EVALUATION (JACE) IN THE FIELD
FOR ARMY, AND AIR FORCE
ALL H-60 AIRCRAFT

DISTRIBUTION STATEMENT A: Approved for Public Release. Distribution is unlimited.

TB 1-1520-237-25-2, dated 15 March 1997, is changed as follows:

1. Remove and insert pages as indicated below. New or changed text material is indicated by a vertical bar in the margin. An illustration change is indicated by a vertical bar next to the figure title. Text that flows to the following page is indicated by the current change number.

Remove pages

1 through 7/(8 Blank)

A-1 through A-4

A-9 through A-12

A-15 through A-20

A-21/(A-22 Blank)

D-3 and D-4

Cover1/(2 Blank)

Insert pages

A/(B Blank)

1 through 7/(8 Blank)

A-1 through A-4

A-9 through A-12

A-15 through A-20

D-3 and D-4

E-1 through E-11/(E-12 Blank)

Cover1/(2 Blank)

2. Retain this sheet in front of manual for reference purposes.

ARMY TB 1-1520-237-25-2
AIR FORCE 1H-60(H)G-6WS-1
C1

By Order of the Secretary of the Army and Air Force:

JOHN P. JUMPER
General, United States Air Force
Chief of Staff

Lester L. Lyles
General, United States Air Force
Commander, AFMC

ERIC K. SHINSEKI
General, United States Army
Chief of Staff

Official:

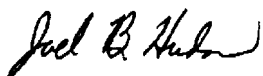

JOEL B. HUDSON
Administrative Asssistant to the
Secretary of the Army

0127503

DISTRIBUTION:

To be distributed in accordance with Initial Distribution Number (IDN) 313687 requirements for TB 1-1520-237-25-2.

LIST OF EFFECTIVE PAGES

Insert latest changed pages; dispose of superseded pages in accordance with regulations.

NOTE: On a changed page, the portion of the text affected by the latest change is indicated by a vertical line, or other change symbol, in the outer margin of the page. Changes to illustrations are indicated by a vertical bar next to figure title. Changes to wiring diagrams are indicated by shaded areas.

Dates of issue for original and changed pages are:

Original	15 March 1997
Change 1	30 August 2002

Total number of pages in this manual is 56 consisting of the following:

Page No.	* Change No.	Page No.	* Change No.
A	1	C-1	0
B Blank	0	C-2 Blank	0
1 and 2	1	C-3	0
3	0	C-4 Blank	0
4	1	D-1	0
5	0	D-2 Blank	1
6 and 7	1	D-3 and D-4	1
8 Blank	0	E-1	1
A-1	0	E-2 Blank	1
A-2	1	E-3	0
A-3	0	E-4 Blank	1
A-4	1	E-5	1
A-5 through A-8	0	E-6 Blank	1
A-9 through A-12	1	E-7 through E-11	1
A-13 and A-14	0	E-12 Blank	1
A-15 through A-17	1		
A-18	0		
A-19 through A-20	1		
A-21	deleted		
A-22 Blank	1		
B-1	0		
B-2 Blank	0		
B-3	0		
B-4 Blank	0		

* Zero in this column indicates an original page.

**POLICY DIRECTIVE GOVERNING THE EXECUTION OF THE
JOINT AIRFRAME CONDITION EVALUATION (JACE)
IN THE FIELD FOR ARMY AND AIR FORCE
ALL H-60 AIRCRAFT**

1.0 INTRODUCTION AND GENERAL INFORMATION

1.1 PURPOSE AND BACKGROUND:

1.1.1 The Joint Airframe Condition Evaluation (JACE) criteria provide a method for the Tri-Service Users of the H-60 derivative airframe to identify candidates that require corrective depot-level maintenance action. This method utilizes a set of common faults, called condition codes, to permit evaluators to make an effective, objective assessment of specific factors judged most critical in determining the need for depot-level maintenance action. This evaluation consists of an examination of the aircraft structure for symptoms of possible hidden defects, together with an assessment of overall system material condition parameters.

1.1.2 These criteria replace the Airframe Condition (ACE), as used previously in the U.S Army and Air Force.

1.1.3 The JACE pertains principally to structural parts that are replaceable at depot-level; however, abnormal conditions and/or defects observed will be recorded for disposition at the appropriate level of maintenance. This evaluation does not pertain to components or time change items, except as how they impact overall maintenance.

1.1.4 This directive, along with the Implementation Plan defines the actions required and the responsibilities of the affected organizations in order to replace the current ACE inspection programs with the JACE.

1.1.5 A Corrosive Prevention and Control Evaluation (CPCE) is defined in Appendix E.

2.0 GOVERNING POLICY

2.1 APPLICABILITY

2.1.1 **Aircraft:** Aircraft that are encompassed by this JACE directive include the following:

Army The UH-60A/L, EH-60A/L, and MH-60A/L/K BLACK HAWK aircraft.

Deleted

Air Force The HH-60G PAVE HAWK aircraft.

2.1.2 **Inspection Intervals:** All aircraft, except as noted in paragraph 2.2 are to be evaluated each year within a period of minus 6 months to plus 90 calendar days of either of the following dates:

- (a) The calendar date of the expiration of the aircrafts Initial Operating Period (IOP).
- (b) The calendar date of the annual anniversary of the IOP after the IOP has expired.

2.2 EXCEPTIONS: The following instances constitute the only approved exceptions to the policy provisions specified in paragraphs 2.1.1 and 2.1.2:

(a) Aircraft that have not yet reached the end of their IOP, which is defined as follows: A period of 36 consecutive months, after having been placed into service from a new condition, or after having been placed into service following the completion of an approved, comprehensive On Condition Maintenance (OCM) for Army or Air Force; Refurbishment for Army; Joint Depot Level Maintenance (JDLM) for all).

(b) Aircraft which have exceeded their IOP, but have not been ACE/JACE will not be placed in non-flyable status. These aircraft will be prioritized for scheduling initial JACE inspection.

(c) Aircraft that are accident, storm, crash and/or battle damaged, or undergoing a depot level repair operation to correct accident, storm, crash and/or battle damage. Aircraft placed into service from depot-level repair action may be subject to remedial actions as defined in paragraph 2.2.2.

(d) Aircraft undergoing a comprehensive, depot-level modification action, approved by the affected service, where the induction date occurs prior to the minus 6-month window, and/or the delivery date exceeds the plus 90-day window. Aircraft placed into service from the depot-level modification action may be subject to remedial actions as defined in paragraph 2.2.2.

(e) Aircraft deployed to an area duly designated by proper authorities within the DoD as a Combat/Hazardous Duty Zone. Aircraft exempted by this provision are subject to remedial actions as defined in paragraph 2.2.2.

(f) Aircraft deployed to a remote exercise site or aboard an under way vessel, whether or not the vessel (aircraft) is deployed in a Combat/Hazardous Duty Zone. This provision does not preclude the option of conducting an evaluation aboard a vessel or at the remote site if the transportation is provided by the owning unit or if the evaluation can be feasibly scheduled and completed coincidentally with a port call, provided that the port is not in a Combat/Hazardous Duty Zone. Aircraft exempted by this provision are subject to remedial actions as defined in paragraph 2.2.2.

(g) Any aircraft exempted specifically by order of command authority equal to or greater than those listed below.

Army: HQ DA (DALO-AV/DAMO-FDV)

Deleted

Air Force: MAJCOM Logistics Management Office

Aircraft exempted by this provision are subject to remedial actions as defined in paragraph 2.2.2 unless relieved specifically from this requirement by the appropriate command authority.

2.2.1 **Exemption Records:** The affected service shall be responsible for maintaining records of all aircraft exempted from the evaluation for any of the reasons defined herein, and shall transmit those records to the Trend Analysis Database System Administrator for incorporation into the database, and to the JACE schedule administrator, where applicable. The record must indicate the aircraft tail number; exemption rationale and authority; and the planned remedial action to be taken.

2.2.2 **Remedial Actions:** Aircraft exempted from the evaluation, as defined in paragraph 2.2, with the exception of aircraft that have not yet reached the end of their IOP, shall be subject to the following remedial actions, except as noted in paragraph 2.2(f).

(a) Aircraft that have been damaged by crash or combat operations shall have the provisions of the JACE satisfied coincidentally with damage assessment and repair estimate inspections. While no scoring data will be generated or reported, indicators or conditions uncovered shall be included in the repair estimate, and decisions regarding disposition shall be made by the affected service.

(b) Aircraft that are undergoing a comprehensive, depot-level modification action, as defined by paragraph 2.2 (c), may have the provisions of the JACE satisfied coincidentally with that modification action by the agency (Government or Contractor) conducting the modification action. The affected service may elect to postpone the JACE until after the completion of the modification action and subsequent delivery to the Government. In this event, the aircraft shall be subject to a maximum operational time limit that shall not exceed 30 consecutive calendar days from the date of Government acceptance, or 50 total flying hours from the logbook time of Government acceptance, whichever is the lesser. At the expiration of this time limit, the aircraft shall be placed into a nonflying status until such time as the JACE is conducted.

(c) Aircraft deployed to a Combat/Hazardous Duty Zone, a remote field exercise site, and/or aircraft deployed aboard an under way vessel, shall be subject to a maximum operational time limit that shall not exceed 30 consecutive calendar days from the date of return from the deployment, to Continental United States (CONUS) and/or an Outside Conus (OCONUS) location not designated as a Combat/Hazardous Duty Zone, or 50 total flying hours from such return from the deployment, whichever is the lesser. At the expiration of this time limit, the aircraft shall be placed into a nonflying status until such time as the JACE is conducted.

(d) Aircraft exempted by virtue of command authority shall be subject to a maximum time limit for operation after release from command authority, as specified by the command authority granting the exemption, at the time of the release. At the expiration of that time limit, the aircraft shall be placed on a priority schedule until such time as the JACE is conducted.

2.2.3 **Remedial Action Records:** The affected service shall be responsible for maintaining records of the remedial actions taken for any aircraft exempted for any reasons specified herein, and shall transmit those records to the Trend Analysis Database System Administrator for incorporation into the database. The records must include the aircraft tail number, action taken, result (score), and the date of the completion of the action.

2.3 **DEFECT CORRECTION:** Correction of defects uncovered as a result of JACE is driven by two criteria: defect severity and corrective action maintenance level. The guidelines for this policy are provided below:

2.3.1 **Minor:** All Minor defects identified during the JACE inspection, correctable at the Organizational/Intermediate (O/I) level, may be corrected at the convenience of the Unit Commander, or a designated representative, hereinafter referred to as Unit Commander. By definition, a minor repair should be correctable at the unit level.

2.3.2 **Major:** Major defects identified during the JACE inspection, falling within similar guidelines, also may be correctable at the O/I level at the convenience of the Unit Commander. However, according to the nature of the severity of the defect, every effort should be made to correct the defect at the earliest possible opportunity. Major defects that are identified as correctable at the depot level require that the Unit Commander and the affected service determine the impact of the defect on the unit's operational schedule, and ensure that required actions are scheduled as expeditiously as possible to minimize the impact on the operational unit.

2.3.3 **Critical:** Critical defects categorized by unit and affected service identified during the JACE inspection will be corrected before the aircraft is put back in service. The evaluation team, Unit Commander, and the affected service will determine the level of maintenance for the repair. If the repair is at the depot level, the affected service will be responsible for scheduling either depot field team or depot induction to evaluate or correct the defects. The repair will be scheduled expeditiously as possible to minimize the impact on the operational unit.

2.4 EVALUATION TEAM:

2.4.1 **Team Composition:** A minimum evaluation team shall be composed of a Team Leader and an Evaluator. The Team Leader shall function as the Principal Point of Contact (PPOC) with the unit personnel and the affected services, and shall provide direction and oversight for the evaluator(s) for which he exercises lead person authority.

2.4.2 **Orientation Seminar:** The JACE orientation administrator shall be responsible for the development and/or review and approval of programs designed to familiarize personnel for service as JACE Team Leaders or Evaluators, and the review and approval of the experience, qualifications, and capability of personnel applying to perform the JACE. Participating services shall assist the administrator in this effort.

2.4.2.1 **Syllabus:** At a minimum, a syllabus should consist of a classroom and an aircraft (lab) phase to ensure that a qualified candidate gains proficiency in the following areas:

- (a) JACE directive policy and technical requirements.
- (b) Individual service's (Army, Air Force) maintenance forms and records.
- (c) Reporting and documentation requirements.
- (d) Defect identification and severity classification.
- (e) Defect correction maintenance level and repair alternatives (depot vs. field team).
- (f) Field site protocol.
- (g) Use of necessary tools and equipment.

2.4.2.2 **Orientation:** The Army shall be responsible for initial and recurrent qualification of personnel and seminar syllabi. Initial orientation shall ensure that trainers are proficient in all aspects pertinent to the JACE program, that evaluators have mastered the necessary knowledge deemed minimum for their assigned level, and that seminar syllabi are sufficient and effective for continued use. Recurrent orientation shall be conducted annually for those years in which new evaluation personnel are involved or when evaluation procedures change. Recurrent orientation shall include syllabi that have been updated as required by program changes, and requires that trainers and evaluators demonstrate the requisite mastery of knowledge and skills needed to continue in their assigned roles.

2.4.2.3 **Personnel Experience and Qualifications:** The following defines the minimum experience and qualifications necessary for individuals to attend the orientation seminar and apply for Team Leader, Evaluator, or Trainer positions:

Team Leader

- (a) Possesses the qualifications of an Evaluator, and has six years of total experience in aircraft maintenance, with two years of experience as a qualified technical inspector/inspector authorization (TI/IA) in either the military or civil sector within the last five years.

(b) Two years of total experience in H-60 type (any service derivative) aircraft maintenance within the last five years.

(c) FAA Airframe and Power plant (A&P) license and 10 years of total experience may be substituted for TI/IA experience.

Evaluator

(a) Four years of total experience in aircraft maintenance in either the military or civil sector within the last five years.

(b) One year of total experience in H-60 type (any service derivative) aircraft maintenance, within the last five years.

(c) FAA A&P license and six years of total experience may be substituted for H-60 experience.

Trainer

(a) Possesses the qualifications required to be certified as a Team Leader, and has three years of experience as an aircraft maintenance technical trainer in either a military or civil sector technical school.

(b) FAA A&P license, 10 years of total experience, and five years of technical training experience may be substituted for TI/IA experience.

2.5 REPORTING AND DOCUMENTATION:

2.5.1 Reports: The JACE results will be reported to the Unit Commander for corrective actions, and to the Trend Analysis Database Administrator. The JACE Team will use the JACE automated database to complete the JACE Administrative Procedures Form, the JACE Checklist, and Discrepancy Summary Form(s) in accordance with this Technical Bulletin (TB) Appendix B. The JACE Team will enter the JACE results in the automated JACE database and print the JACE Summary Report. The Summary Report at minimum will contain all the information from the JACE Administrative Procedures Form, the JACE Checklist results, and the Discrepancy Summary Forms. The Summary Report will be used to brief the Unit Commander on the results of the JACE. The aircraft records will be annotated, and a signed copy of the Summary Report (Administrative Procedures Form, JACE Checklist, Discrepancy Summary Form(s)), and a copy of the results on computer disk will be forwarded to the Trend Analysis Database Administrator for incorporation into the Joint database. After the database administrator verifies the data from the Summary Report with the data transmitted from the field, the Summary Report and a copy of the computer disk will be forwarded to the affected service. The JACE team leader will upload the aircraft's JACE summary reports to the JACE administrators bulletin board daily. All aircraft that were scheduled but not available for the evaluation over the period of the stay, immediately report the aircraft serial number to the affected service PPOC and JACE Project Officer.

2.5.2 Unit Out-briefing: The JACE Team Leader shall provide an out-briefing to the Unit Commander on the JACE results. The briefing will be consistent with the overall aircraft condition reported on the Summary Report. The Unit Commander or representative will sign the Summary Report (JACE Checklist, Discrepancy Summary Form(s), and Administrative Procedures Form), and a copy of the Summary Report will be provided to the Unit Commander.

2.5.3 Aircraft Record Entry: The JACE Team Leader will annotate each aircraft record with the JACE inspection date and signature.

2.5.4 **Record Keeping:** The affected service will maintain the original JACE Summary Report.

2.6 RESPONSIBILITIES AND AUTHORITY:

2.6.1 **Evaluation Team:** The evaluation team will be responsible for accomplishing the JACE and reporting the results. The JACE Team is authorized by the affected service to evaluate and classify defects identified during the conduct of the inspection, to document and report these defects to the Unit Commander, and to recommend to the affected service and Unit Commander the disposition of the defect and flying status of the aircraft, prior to any necessary repair actions.

2.6.2 **Unit Commander:** The Unit Commander is responsible for ensuring that the aircraft to be inspected are made available to the team, and have been prepared as specified in the official publication of JACE procedures. The Unit Commander is responsible for ensuring that the team is provided access to a working space and phone and/or fax capabilities. After review and acceptance of the evaluation team's report, the Unit Commander is responsible for negotiating the schedule and nature of maintenance action for major and critical defects.

2.6.3 **Affected Service Principal Point of Contact (PPOC):** The PPOCs (lead and participating) are responsible for ensuring that all Government interests are met, and all requirements of the JACE are accomplished for the respective service. The PPOC also is assigned responsibility and authority to perform all, or portions of, airframe depot program management functions to support the JACE effort. The JACE process shall be subject to evaluation and certification by the PPOCs to determine its effectiveness in supporting the requirements established in this directive, drawings, Technical Instructions, Technical Orders (T.O.s), Technical Manuals (TMs), and other supporting documents. The designated PPOC for each service is as follows:

Army: Department of the Army
Headquarters
Building 131, Midway Street
Mail Stop 55
Corpus Christy Naval Air Station
Corpus Christy, Texas 78419

Deleted

Air Force: Department of the Air Force
Warner Robins Air Logistics Center/LUH Special Operations Forces System Program Office
226 Cochran Street
Robins AFB GA 31098-1622

2.6.4 **Trend Analysis Database Administrator:** The database administrator is responsible for the storage and maintenance of all JACE records received. The administrator also provides data as needed for each service to develop respective reports and summaries. Administrator will assure that the database contains a complete record for all aircraft that have been JACE evaluated.

2.7 REPORTING OF ERRORS AND RECOMMENDING IMPROVEMENTS.

You can improve this TB. If you find any mistakes or if you know of a way to improve these procedures, please let us know. Mail your letter or DA form 2028 (Recommended Changes to Publications and Blank Forms), or DA Form 2028-2 located in the back of this manual, directly to: Commander, US Army Aviation and Missile Command, ATTN: AMSAM-MMC-MA-NP, Redstone Arsenal, AL 35898-5000. A reply will be furnished to you. You may also provide DA Form 2028 information to AMCOM via e-mail, fax, or the World Wide Web. Our fax number is: DSN 788-6546 or Commercial 256-842-6546. Our e-mail address is: 2028@redstone.army.mil. Instructions for sending an electronic 2028 may be found at the back of this manual immediately preceding the hard copy 2028. For the World Wide Web use: <https://amcom2028.redstone.army.mil>.

**APPENDIX A
TECHNICAL PROCEDURES**

JOINT AIRFRAME CONDITION EVALUATION(JACE)

1.0 INTRODUCTION AND GENERAL INFORMATION

1.1 PURPOSE AND BACKGROUND:

1.1.1 The Joint Airframe Condition Evaluation (JACE) criteria provide a method for the (Department of Defense (DoD)) Users of the H-60 derivative airframe to identify candidates that require corrective depot-level maintenance action.

1.1.2 These criteria replace the Airframe Condition Evaluation (ACE), as used previously in the U.S. Army and Air Force.

1.1.3 The JACE pertains principally to structural parts that are replaceable at depot level.

1.2 SCOPE: This publication will provide the JACE evaluators with the information required to perform JACE satisfactorily.

1.3 EQUIPMENT AND PUBLICATIONS

1.3.1 The following equipment must be in the possession of each member of the JACE Team:

- (1) Inspection mirrors (2 each).
- (2) Flashlights (2 each) and spare batteries.
- (3) Pocket magnifying lens - 10X (1 each).
- (4) Pointed probe (1 each).
- (5) Caliper or other suitable tool for measuring fastener diameters (1 each).

1.3.2 In addition to the specific equipment required by each team member, the following equipment must be in the general possession of each JACE Team:

- (1) Portable computer (1 each) with the following minimum capability: IBM PC compatible (120 megabyte (Mb) hard drive) with an internal faxmodem (14.4 Kbps, V3.2bis compatible) and appropriate communications software.
- (2) JACE electronic data form executable file backup program disk (1 each) (GFE).
- (3) Blank data diskettes (high density), quantity adequate for mission needs.

1.3.3 Technical publications; Army and Air Force administrative publications; and other useful publications should be available in the libraries of the installations or units visited, if needed. This document represents the only technical publication that the JACE Team must possess.

1.4 CHANGE RECOMMENDATIONS: The reporting of errors, omissions, and recommendations for improving this publication or any other technical publications by individual users is encouraged. Change recommendations should be submitted on a publications change request, and forwarded to the appropriate PPOC, as indicated in this TB.

1.5 APPLICABILITY: Aircraft that are encompassed by this JACE publication include the following:

Army: The UH-60A/L, EH-60A/L, and MH-60A/L/K BLACK HAWK aircraft.

Deleted

Air Force: The HH/MH-60G PAVE HAWK aircraft.

1.6 DEFECT IDENTIFICATION AND CLASSIFICATION: Each JACE condition code and any other noted defects have three possible defect classifications. After examining the defect, classify it as either minor, major, or critical, depending on the severity of the defect. The defect classification and criteria are listed below:

1.6.1 **Minor Defect:** A defect that is not likely to materially reduce the usability of a system or component for its intended purpose; or is a departure from established standards having no significant bearing on the effective use or operation of the system or component.

1.6.2 **Major Defect:** A defect greater than minor limits that requires repair or replacement of the part to restore the full load carrying capacity of the structure. All cracks are considered major defects.

1.6.3 **Critical Defect:** Any defect that results in a hazardous or unsafe condition for persons operating the aircraft, or a defect that is likely to prevent performance of the tactical function of the aircraft. All critical defects shall be briefed to the Unit Commander or his designated representative (hereafter referred to as the Unit Commander), and the affected service on the discovery of the defect.

1.7 REPORTING AND DOCUMENTATION: The JACE team will complete the JACE administrative procedures form, the JACE checklist, and the discrepancy summary forms for all the major and critical defects using the automated JACE database during the execution of the JACE.

1.7.1 **JACE Administrative Procedures:** The Administrative Procedures Form provides the JACE Team with the aircraft background, and provides the services with information to assist in trend analysis of the aircraft or fleet. Information to complete the form can be gathered from the aircraft logbook. An example of the Administrative Procedures Form is provided in Appendix B.

1.7.2 **JACE Report Form:** The JACE Report is the completed JACE Administrative Procedures Form, JACE Checklist, and Discrepancy Summary Form(s). The JACE Team will complete the JACE Checklist for each indicator when the item is inspected. Using the automated JACE data base, select the appropriate defect(s) or no defect, and classify the defect(s) as Minor, Major, or Critical.

1.7.3 **Unit Out-briefing:** The JACE Team Leader shall provide an out-briefing to the Unit Commander on the JACE results. The briefing will be consistent with the overall aircraft condition reported on the Administrative Procedures Form. A copy of the JACE Checklist, Discrepancy Summary and Administrative Procedures Form will be provided to the Unit Commander.

1.7.4 **Aircraft Record Entry:** The JACE Team Leader will annotate each aircraft record with the JACE inspection date and signature.

1.7.5 **Record Keeping:** The PPOC for the affected service will maintain the original JACE Administrative Procedures Form, Discrepancy Summary Form(s), and Checklist. The Administrative Procedures Form, Discrepancy Summary Form(s), and JACE Checklist will be filed by aircraft tail number, and will be maintained until the aircraft undergoes a comprehensive depot-level rework program.

2.0 TECHNICAL REQUIREMENTS

2.1 ACCOMPLISHING THE JACE: The JACE Team is responsible for the overall conduct of the JACE in accordance with this directive. The unit, at a minimum, will provide a unit Quality Assurance (QA) representative and an aircraft technician(s), as necessary, to assist the JACE Team.

2.1.1 Local Briefing and Setup:

- (a) The Unit Commander will provide an orientation briefing to the JACE Team. The briefing will include safety issues, local procedures for exiting and entering aircraft inspection area, access to a telephone and telephone procedures, access to a desk and work area, location of technical data, and aircraft peculiarities. The aircraft records will be made available to the team.
- (b) The Unit Commander will ensure that the aircraft is prepared for the inspection. Specifically, all access and inspection doors and panels will be removed in accordance with paragraph 2.2.2.
- (c) The briefing will identify the PPOC for the affected service, evaluation team members, and any new procedural changes, and will provide an explanation of how the JACE will be executed at the unit.

2.1.2 **Aircraft Location:** The Unit Commander will ensure all scheduled aircraft are available for the inspection. Aircraft should be positioned to allow for maximum effectiveness of the team's time. Also, where possible, aircraft will be placed in a hangar to facilitate the inspection. If convenient, the Unit Commander will provide transportation for the evaluation team when aircraft are at a remote site within a two-hour one-way flight from their home field or base. The Unit Commander will arrange the flight and maintenance schedules to ensure that the inspection is not delayed unduly due to aircraft nonavailability.

2.1.3 **Problem Resolution:** If a JACE-related problem arises that cannot be resolved locally, the problem will be addressed to the PPOC of the affected service for resolution/mediation.

2.1.4 **Exit Briefing:** The JACE Team Leader shall provide an exit briefing on the inspection results. The briefing will convey to the Unit Commander the presence of any major and/or critical defects by aircraft serial number. The Unit Commander shall sign the JACE Checklist to indicate that the briefing has been accomplished, and the Team Leader shall provide a copy of the JACE Checklist, Administrative Procedures Form, and Discrepancy Summary Form(s) to the Unit Commander.

2.2 AIRCRAFT EXAMINATION:

2.2.1 **Administrative Procedures:** Examine the aircraft record and complete items 1-18 on the Administrative Procedures Form. After the inspection, complete items 19, 20, and 21. Instructions to complete the form follow.

NOTE

For Air Force aircraft, use AFTO Form 95; for Army aircraft, use DA Form 2408 series, and others, in the aircraft log book and the aircraft logbook to complete the following aircraft information:

- (1) **TODAY'S DATE:** Enter date.
- (2) **INSPECTOR CODE:** Enter inspector identification code.
- (3) **INSPECTION AGENCY:** Enter inspection agency designation.
- (4) **UNIT:** Enter unit designation, address, and branch of service.
- (5) **LOCATION:** Enter base, post, station, or geographic location where the aircraft is being inspected.
- (6) **AIRCRAFT MODEL:** H-60.
- (7) **MANUFACTURE YEAR:** Enter year of aircraft manufacture.
- (8) **SERIAL NUMBER:** Enter aircraft serial number.
- (9) **TOTAL HOURS ON AIRCRAFT:** Annotate total hours on aircraft.
- (10) **NUMBER OF TIMES AIRCRAFT HAS UNDERGONE A COMPREHENSIVE REWORK:** Annotate the number of times the aircraft has been reworked or the aircraft's current service tour number. If new, enter 00, then skip to Block 16.
- (11) **COMPREHENSIVE DEPOT REWORK BY:** Identify the agency that performed the last rework.
- (12) **AIRCRAFT HOURS AT TIME OF REWORK:** Annotate hours at the time of last rework.
- (13) **DATE OF REWORK:** Annotate month and year of last rework.
- (14) **DATE OF LAST AIRCRAFT CONDITION EVALUATION (ACE) OR JACE:**
Annotate the date of the last ACE/ASPA or JACE. If this is the first inspection, leave blank.
- (15) **NUMBER OF PRIOR JACE INSPECTIONS or ACE INSPECTION SEQUENCES:** Write the number of prior JACE Inspections or ACE Inspections Sequences since last rework. If the aircraft is new, enter 0.
- (16) **HOURS AT LAST PHASE INSPECTION (PI):** Annotate aircraft hours at last PI.
- (17) **AIRCRAFT HISTORY:** In narrative form, report any damage, over stress, hard/overweight landings, chronic maintenance/system problems, and special operating conditions recorded in the aircraft logbooks and maintenance records. Include any record of crash damage, saltwater immersion, or other notable/unique events that may have a long term impact on the airframe.
- (18) **LIFE LIMITED STRUCTURAL ITEMS:** Review life limited structural components installation data. Compare present operating hours to published operational limits in

technical data. Identify components whose service life will expire before the next JACE using the preceding year flying hours. Structural components found exceeding their service life limit will be recorded as a critical defect, and structural components found with service life projected to expire prior to next JACE inspection will be identified.

- (19) **OVERALL AIRCRAFT CONDITION:** Complete this information after all other items of the JACE have been performed. In narrative form, report the overall condition of aircraft. Examine surface condition of exterior paint finish, state of corrosion protection, cracking or flaking of paint, indications of skin corrosion under the paint, seam sealing, and sealant. Identify hose assemblies whose service life will expire before next JACE.
- (20) **DISCREPANCY SUMMARY:** Completion of the discrepancy summary is mandatory for all major or critical discrepancies found. The discrepancy summary also is used to provide detailed information, such as frame station and/or the number of loose rivets or fasteners for all discrepancies found and documented on the services appropriate maintenance forms. If none were found, state NONE.

2.2.2 Preparation of Aircraft for JACE (Figure 1):

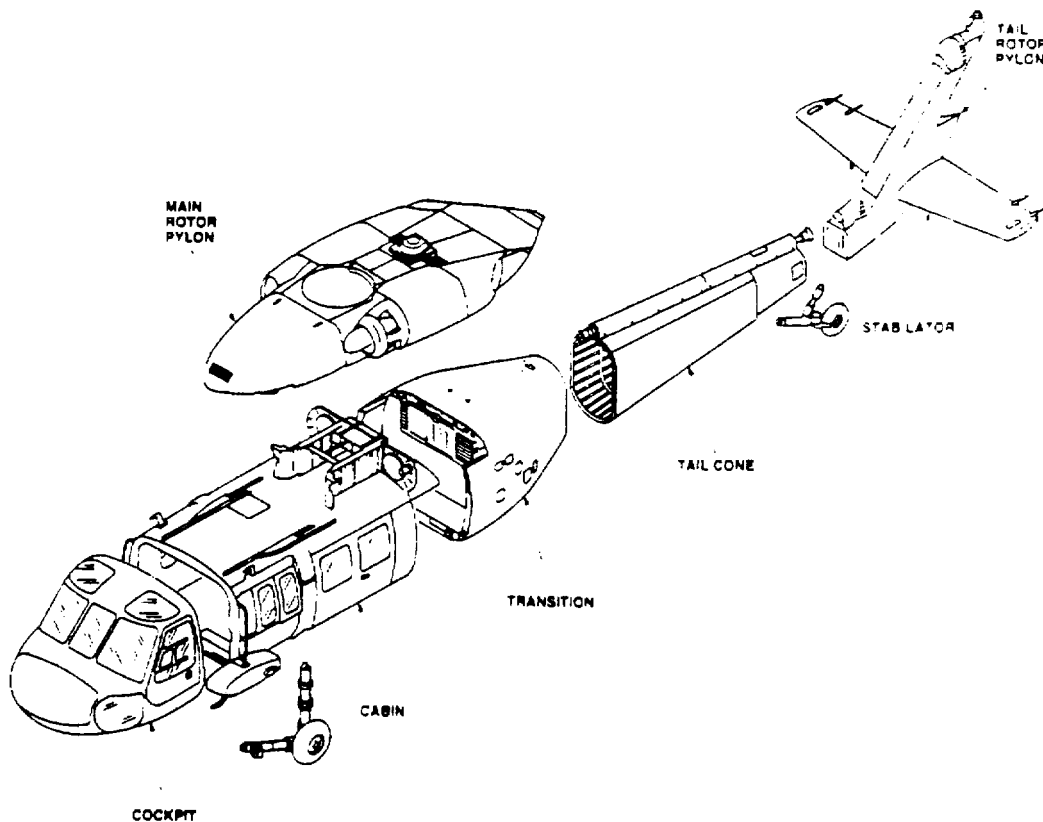

Figure 1. ACCESS PANEL REMOVAL

NOTE

Unlock all doors. Remove any equipment that may restrict the following:

- (1) Open electronic compartment access door.

- (2) Tilt pilot and copilot seats back if tilt capable. Otherwise remove seats.
- (3) Open upper shock strut access doors, and External Stores and Shock Struts hard point fairings.
- (4) Remove soundproofing and drip pan from main transmission. Remove soundproofing from sides and ceiling of cabin interior.
- (5) Remove aft cabin bulkhead doors and cargo netting.
- (6) Open tail rotor drive shaft covers.
- (7) Remove intermediate gearbox fairing.
- (8) Remove tail rotor gearbox fairing.
- (9) Remove tail landing gear shock strut access covers, both left and right. Illustration denotes location for Blackhawk and PAVE HAWK only.)
- (10) Open pylon fairing, cowling, and doors.
- (11) Remove quad bay cover.
- (12) Fold tail pylon section Navy only).

2.2.3 **JACE Indicators and Detailed Inspection Instructions:** The JACE Indicators are grouped by aircraft sections in a functional inspection sequence starting with the nose of aircraft rotating counterclockwise around the aircraft from top to bottom. The JACE Checklist is sequenced in the same order. The detailed inspection instructions by aircraft section and figure references are as follows:

2.2.3.1 Nose Section Evaluation (Figure 2):

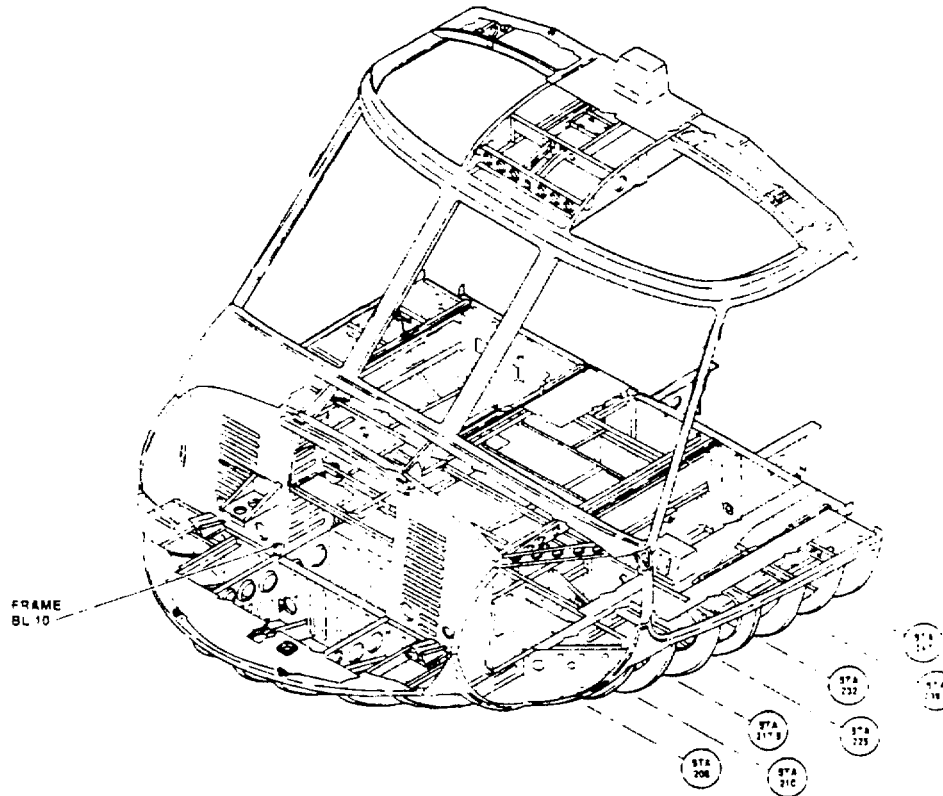

Figure 2. COCKPIT STRUCTURE

- (a) Transparency Frames: Inspect framing and seals of the cockpit transparencies for general deterioration, cracks, corrosion, and loose or missing fasteners.
- (b) Exterior Sheetmetal:
- (1) Examine exterior of the nose section [Fuselage Station (F.S.) 162-247] for evidence of impact damage to skin, corrosion, dents, cracks, buckling, interim repair, and loose or missing fasteners.
 - (2) Inspect skin behind the covers of the radar and float bag bottles for cracks, corrosion, and loose or missing fasteners (SH-60).
 - (3) Examine the pilot and copilot door frames, attach fittings and latch keeps for cracks, excessive wear, interim repair, missing or loose fasteners, punctures, binding, and corrosion. If applicable, check operation of emergency window jettison.
 - (4) Examine the exterior of the Color Weather Radar and Forward Looking Infrared (FLIR), including the mounts, for deterioration, cracks, corrosion, and loose or missing fasteners (Figure 3) (HH/MH-60A/G/K/L).

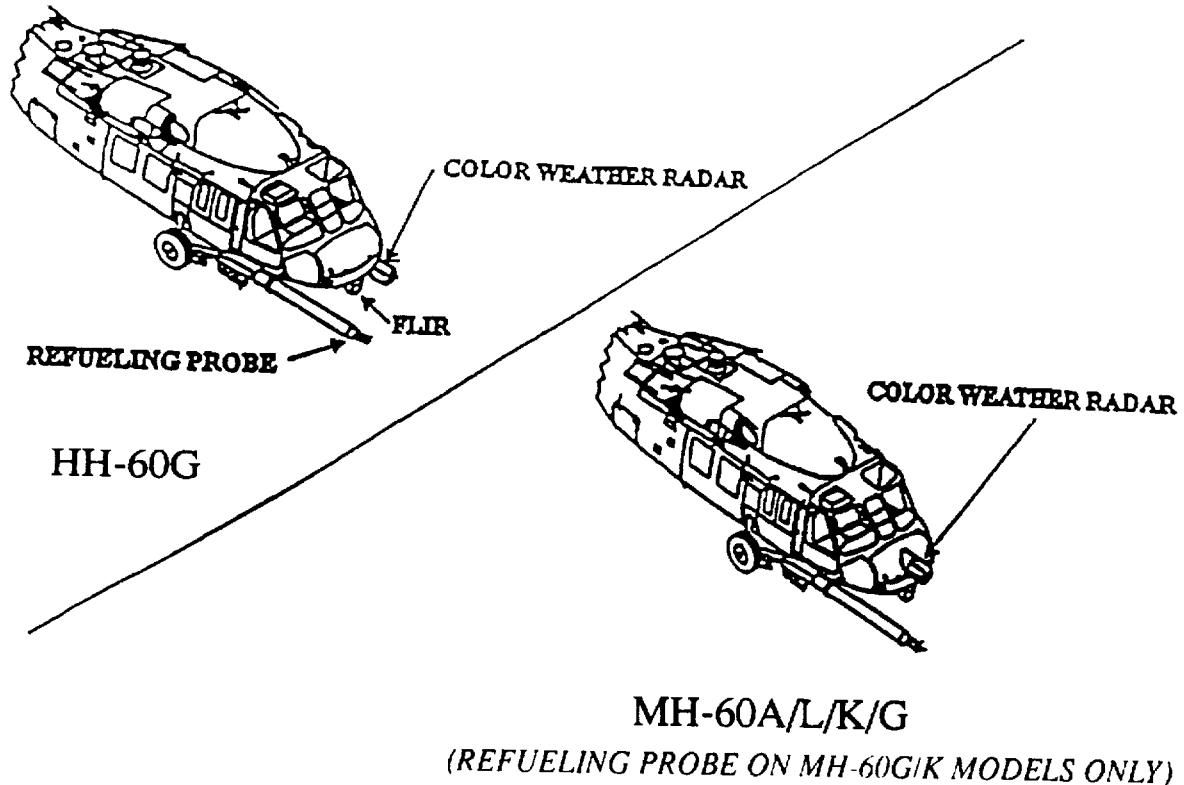

Figure 3. Color Weather Radar and FLIR

(c) Interior Structure:

- (1) Inspect the avionics rack supports and electronics compartment for cracks, corrosion, buckling, and loose or missing fasteners.
- (2) Inspect cockpit floor for punctures, loose or missing fasteners, buckling, and corrosion.
- (3) Inspect nose section framing (F.S. 162-247) and aft cockpit bulkhead (F.S. 247) for evidence of cracks, scratches, dents, corrosion, and loose or missing fasteners.
- (4) Visually inspect all accessible airframe structures under pilot's and copilot's seats (especially Butt Line (B.L.) 13 and B.L. 35) for evidence of excess wear, security, loose or missing fasteners, corrosion, and integrity of seat rails.

- (d) Instrument Panel: Inspect instrument panel supports for cracks, buckling, corrosion, and loose or missing fasteners.

2.2.3.2 Cabin Section Evaluation

- (a) Exterior Sheetmetal: Examine exterior skin of the cabin section (F.S. 247-379) for evidence of dents, cracks, buckling, interim repair, loose or missing fasteners, and corrosion.

- (b) Fuel Probe Mount: Examine the area around the fuel probe mounts for cracks, corrosion, and loose or missing fasteners (HH/MH-60A/G/L).
- (c) Deleted
- (d) Deleted
- (e) Cabin Frame: Visually evaluate the following structures for cracks, excess wear, interim repairs, loose or missing fasteners, punctures, buckling, and corrosion (Figure4):

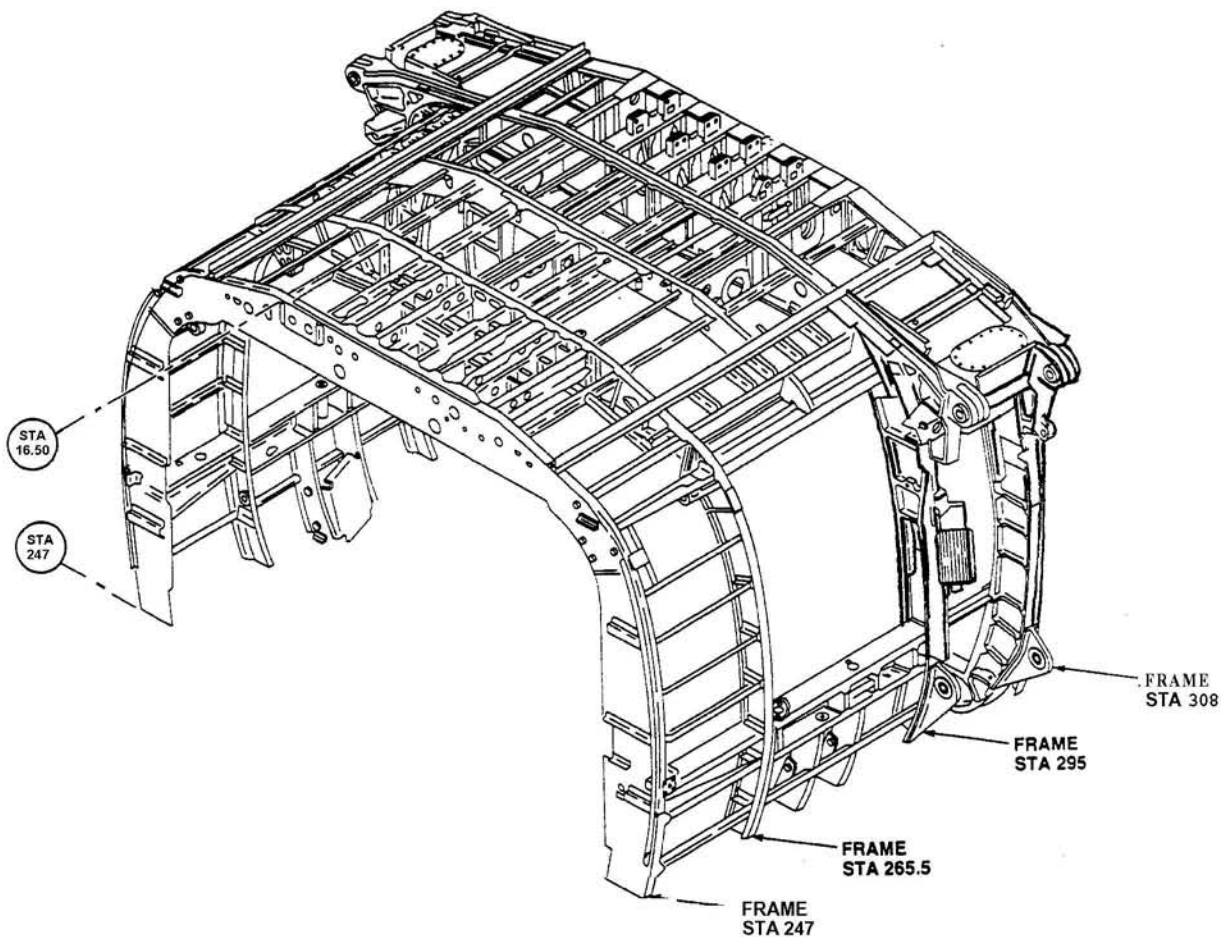

Figure 4. CABIN STRUCTURE (BODY)

- (1) Cabin frames, F.S. 247-295, L/H and R/H.
- (2) Gun support beams, L/H and R/H.
- (3) Cabin frame, F.S. 379, L/H and R/H.
- (f) Examine the following structures for cracks, corrosion, binding, and loose or missing fasteners:

- (1) Cabin door frame, L/H and R/H.
- (2) Cabin door track, L/H and R/H.
- (3) Cabin door latch keep, L/H and R/H.
- (g) Floor Panel Under the Spectrum Analyzer: Check the floor panel under the spectrum analyzer for crushing or delamination due to corrosion. These characteristics may indicate damage to floor support structure.
- (h) Shear Deck Area of the Transmission Support Beams and Rescue Hoist Mounts and fittings (Figure 5):

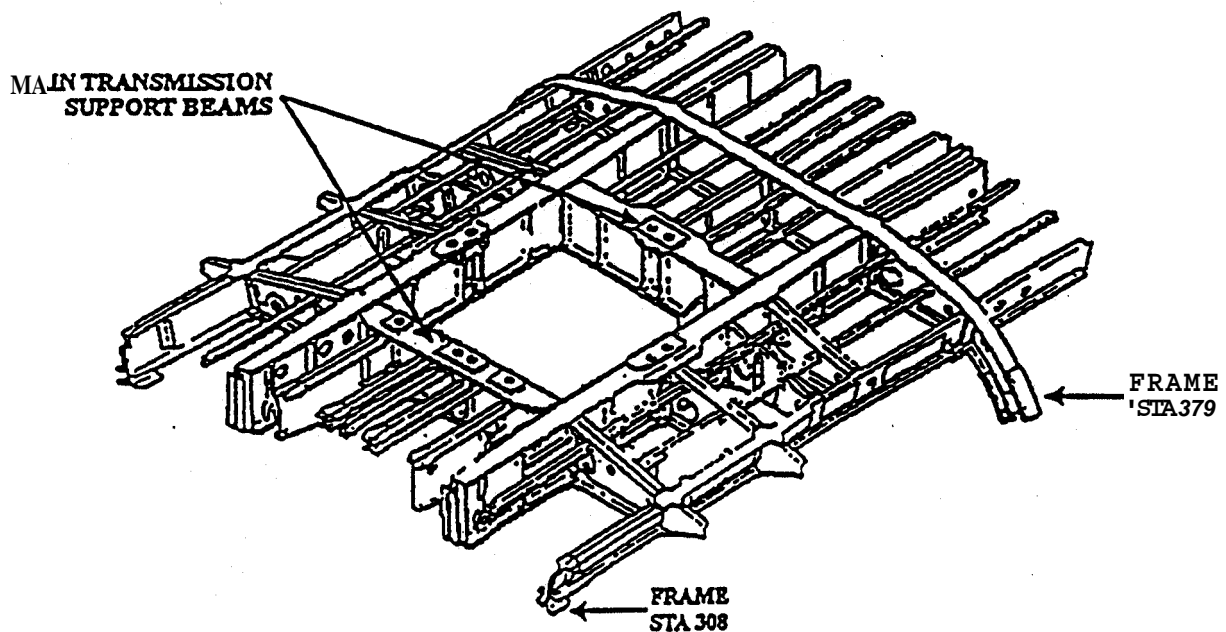

Figure 5. CABIN STRUCTURE (TOP)

- (1) Closely examine the shear deck area of the main transmission support beams, rescue hoist mounts and fittings for cracks; loose or missing fasteners; oversized holes; corrosion; dents; and scratches or nicks. The areas of concern are the following:
 - (a) All shear deck fasteners on the ceiling side between F.S. 361 and 326; B.L. 16.5, L/H and R/H; and outboard.
 - (b) Where the straps overlap the beams on the ceiling side of F.S. 327.115 and 360.065; B.L. 16.5, L/H and R/H; and inboard to the end of the straps.
 - (c) The attachment of the beams at F.S. 327.115 forward end; F.S. 360.065; aft end to B.L. 16.5 beam; and L/H and R/H immediately inboard B.L. 16.5 above waterline 261.

(2) Any discrepancies on working fasteners or oversized holes that require the replacement of a main transmission support beam automatically qualify as a critical defect

- (i) Flight Control Rod Supports and Upper Junction Box: Examine the airframe around the flight control rod supports and upper junction box for evidence of cracks, corrosion, chafing, security, and loose or missing fasteners. Also, check the flight control rods for interference or binding.
- (j) Airframe Structure: Inspect the following structures for evidence of cracks, scratches, dents, loose or missing fasteners, excessive wear, and corrosion (Figure 6):

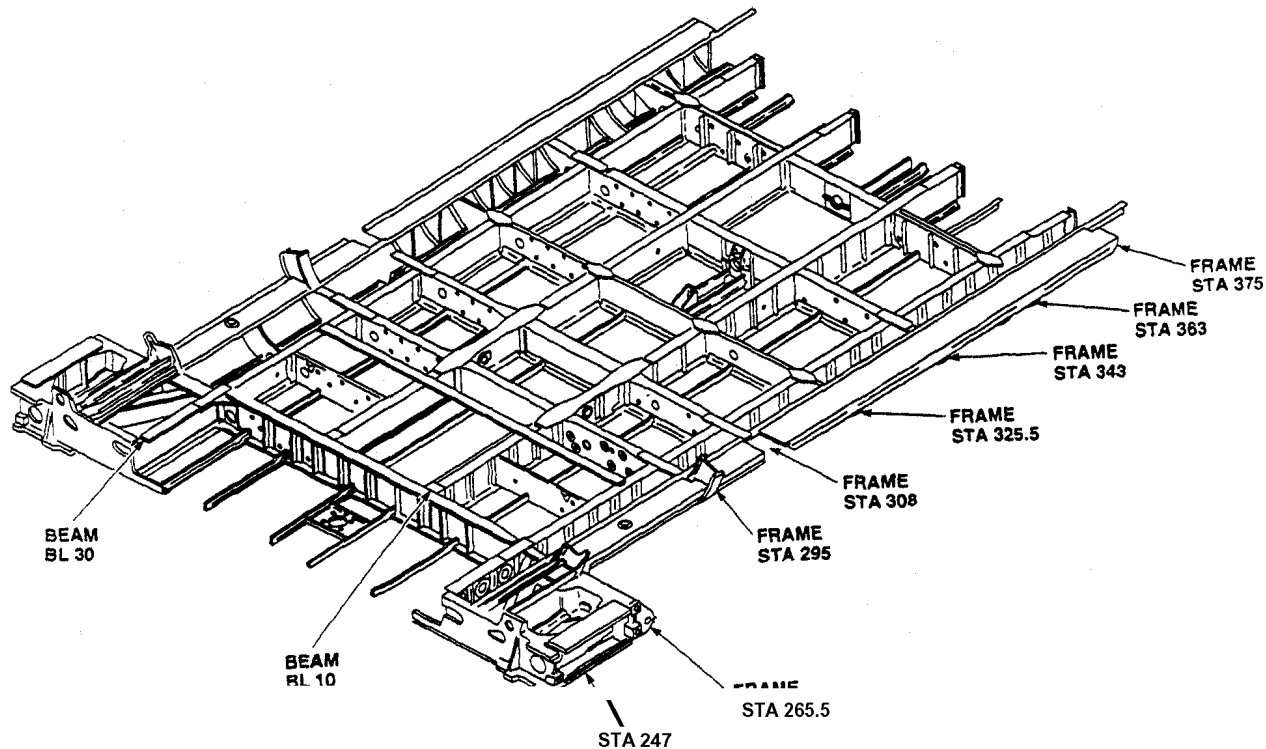

Figure 6. CABIN STRUCTURE (BOTTOM)

- (1) External stores or weapon stub wings mounts and shock strut attach fittings, L/H and R/H.
- (2) Cabin frames, F.S. 308, L/H and R/H.
- (3) Servo Beam Railings and T-Angle Supports.
- (4) Cargo hook support fittings.
- (K) Deleted.
- (l) Deleted.
- (m) Deleted.

2.2.3.3 Transition Section Evaluation.

- (a) Transition Section Interior (Air Force Pave Hawk only): Gain access to the interior of the transition section and inspect for the following conditions (Figure 7).
- (1) Examine stringers and frame for cracks, corrosion, and loose or missing fasteners.
 - (2) Examine interior skins for cracks, interim repairs, corrosion, buckles, and loose or missing fasteners.

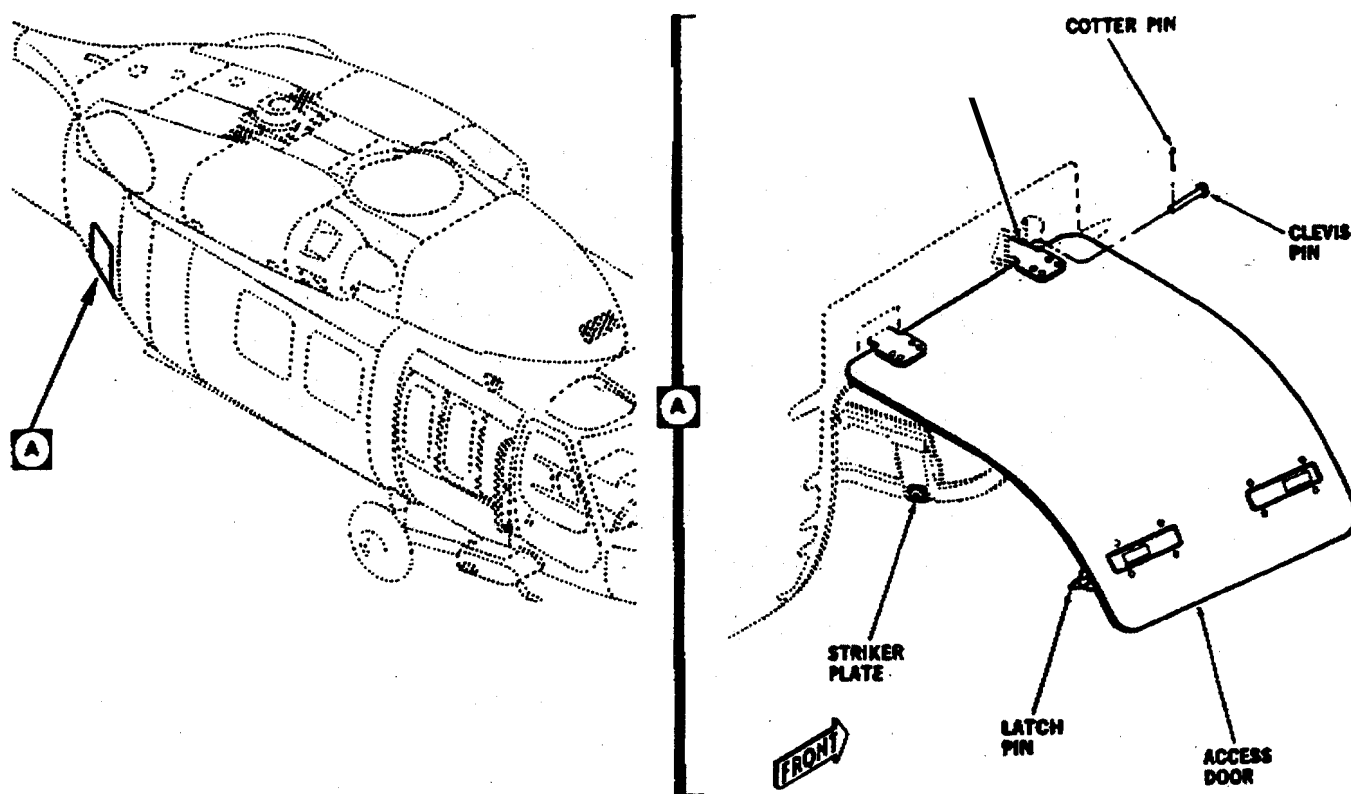

Figure 7. TRANSITION SECTION (AIR FORCE PAVE HAWK ONLY)

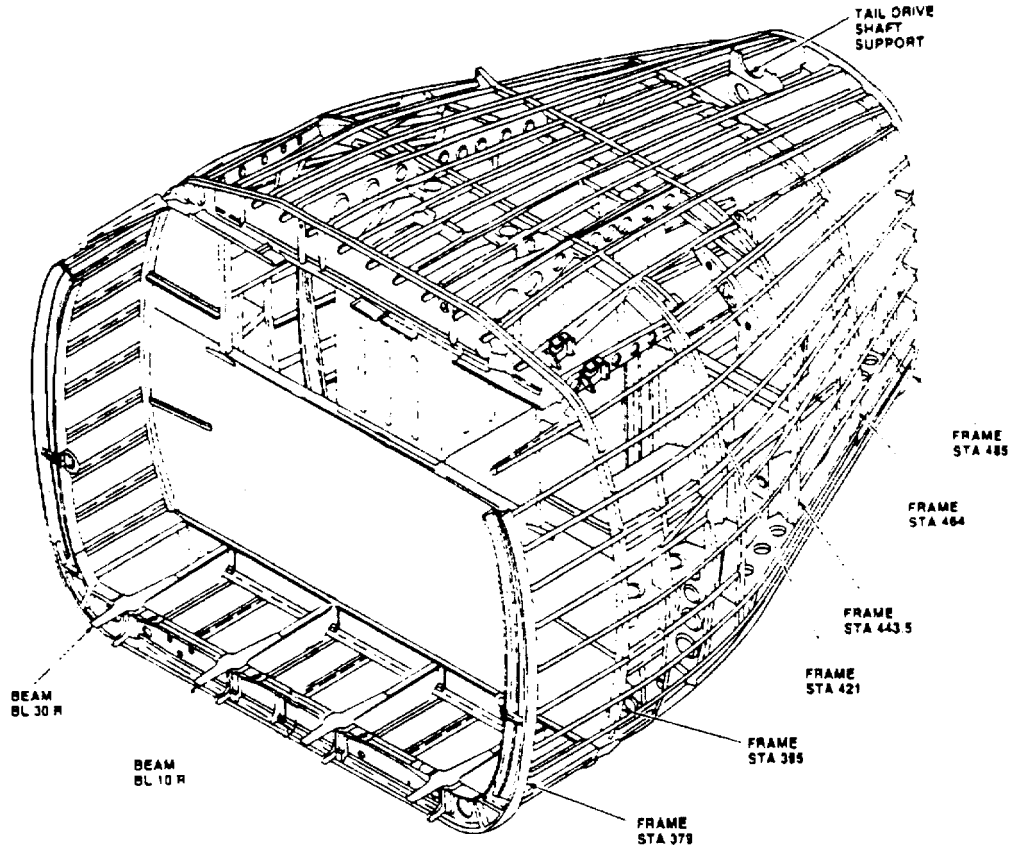

Figure 8. Transition Structure

- (b) Antennas: Check antennas for security, corrosion, deteriorated seal, cracked base, and loose or missing fasteners (Figure 8).
- (c) Drive Shaft Support: Look for cracks, corrosion, loose or missing fasteners, and security.
- (d) Lifting Eye Bolts: Examine the attachment area for cracks, corrosion, and loose or missing fasteners.
- (e) Transition Section Exterior Sheetmetal: Look for punctures, cracks, interim repairs, corrosion, buckles, and loose or missing fasteners.
- (f) F.S. 485: Check for oversized holes, loose fasteners, cracks, corrosion, chafing, interim repairs, and buckles. Check for movement of torque stripes and for fretting residue at each bolt.
- (g) Transition Section Interior: Gain access to the interior of the transition section and inspect for the following conditions.
 - (1) Examine stringers and frames for cracks, corrosion, and loose or missing fasteners.
 - (2) Examine interior skins for cracks, interim repairs, corrosion, buckles, and loose or missing fasteners.

2.2.3.4 Tail Cone Section Evaluation

- (a) Exterior Sheetmetal: Examine the tail cone sheetmetal for cracks, punctures, interim repairs, loose or missing fasteners, buckling, and corrosion.
- (b) Interior: Gain access to the interior of the tail cone section and inspect for the following conditions (Figure 9, sheet 1).

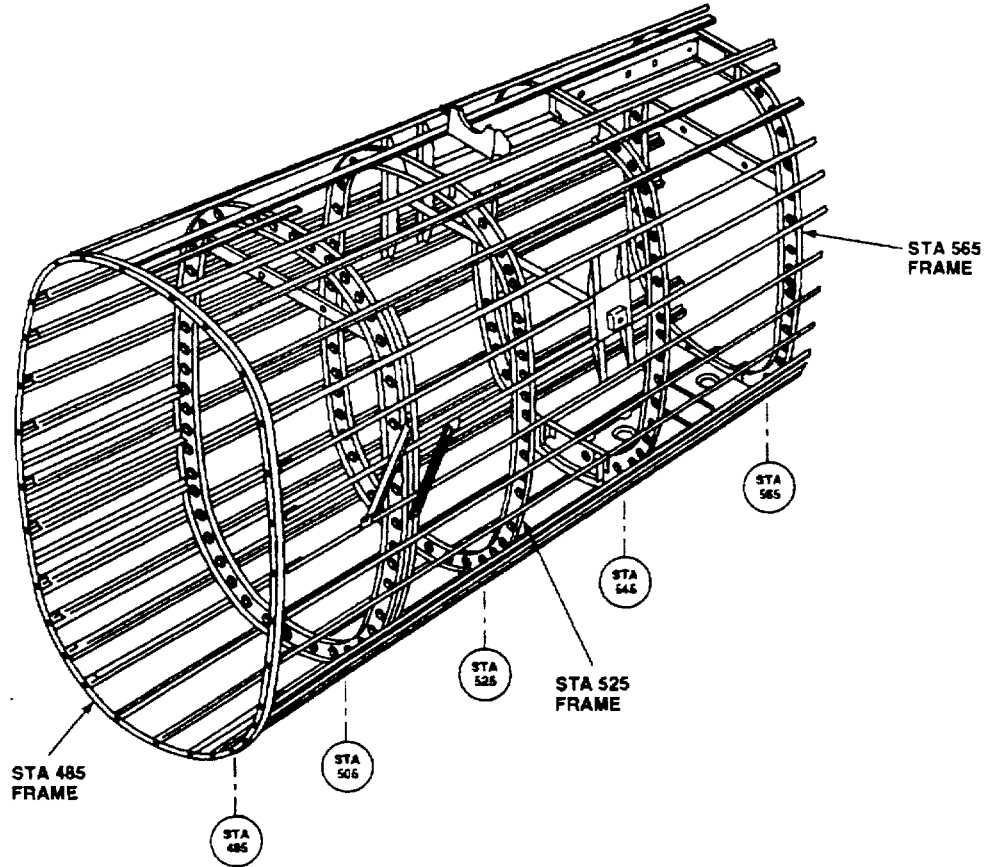

Figure 9. TAILCONE STRUCTURE (Sheet 1 of 2)

- (1) Examine the aircraft skin, stringers, and frames (ribs) for evidence of cracks, corrosion, loose or missing fasteners, buckling, and interim repair.
 - (2) Examine internal stringers, frames, and brackets and supports used for items mounted externally on the tail cone for corrosion, and loose or missing fasteners.
- (c) Tail Rotor Drive Shaft Supports: Examine the tail rotor drive shaft supports for cracks, loose or missing fasteners, and corrosion (Figure 9).

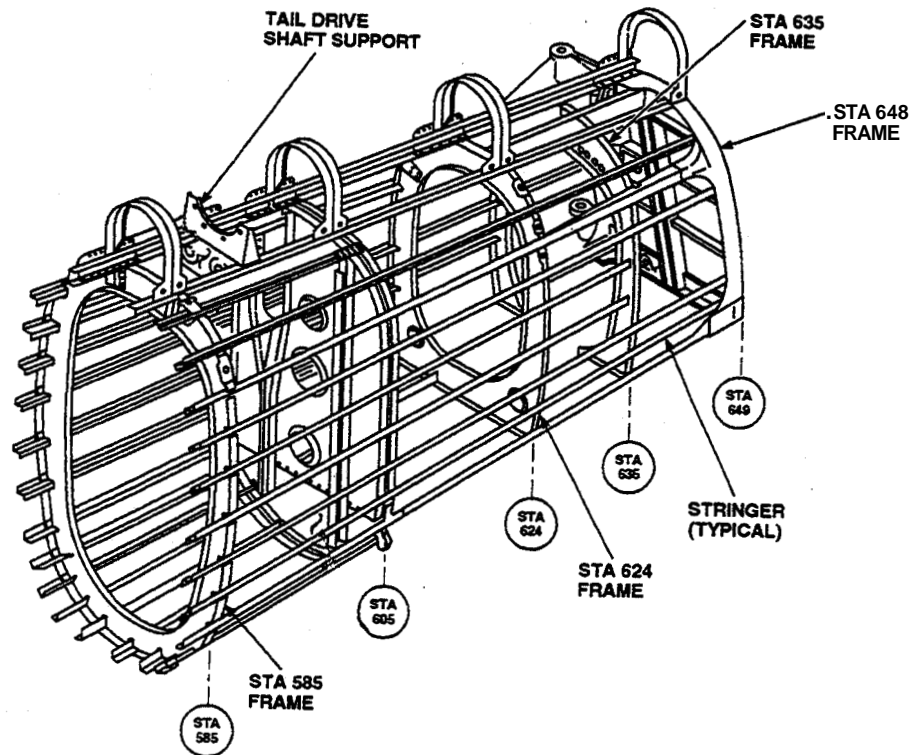

Figure 9. TAIL CONE STRUCTURE (Sheet 2 of 2)

- (d) Bulkhead F.S. 605 (Army/Air Force): Examine the tail cone bulkhead, F.S.605, for cracks, dents, scratches, and corrosion.
- (e) Deleted.
- (f) Area Around the Flight Control Pulleys: Remove the tail cone flight controls access panel and examine the airframe around the area of the flight control pulleys for cracks, corrosion, and loose or missing fasteners.
- (g) Canted Hinge: Examine the tail cone canted hinge bulkhead, F.S.647, for cracks, dents, scratches, excess wear, and corrosion.

Figure 10. Deleted

(h) Deleted.

(1) Any significant wear in the pin puller bushings also requires repair as soon as possible (HH-60H).

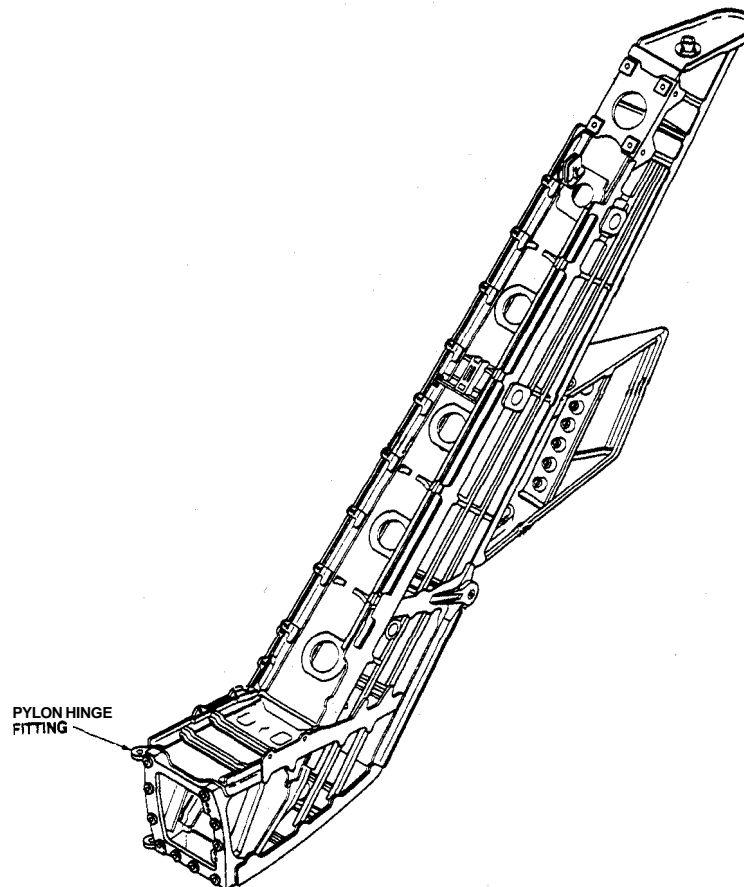

Figure 11. TAIL PYLON STRUCTURE

2.2.3.5 Tail Pylon Section Evaluation: Discrepancies found in the tail pylon section should be noted and considered when evaluating the overall condition of the aircraft. The tail pylon section is not as critical an area as other sections of the aircraft for depot induction. The entire tail pylon can be removed and replaced at the organizational level (Figure 11).

- (a) Exterior Sheetmetal: Examine exterior skin of the tail pylon section (F.S. 647.5 - 762.75) for evidence of dents, cracks, chafing, buckling, loose or missing fasteners, and corrosion.
- (b) Interior: Remove the pylon flight control access panel and inspect accessible interior for evidence of cracks, corrosion, and loose or missing fasteners. Examine the lower step guide pin for security, and examine the surrounding pulleys for damage. Also, examine the airframe under the tail rotor drive shaft and the skin where the drive shaft and gearbox access panels attach for excess wear, cracks, corrosion, security, and loose or missing fasteners.
- (c) Deleted.
- (d) Intermediate and Tail Gearbox Mounts: Inspect the mounting areas the intermediate and tail gearboxes for cracks, corrosion, loose or missing fasteners, and deterioration of sealant.
- (e) Stabilator and Tail Skid: Check the stabilator and tail skid for security, cracking, excess wear, loose or missing fasteners, and corrosion.

- (f) Antenna Mounts (MH and HH/MH models): Examine antenna mounts for corrosion, chafing, cracks, security, deteriorated sealant, and loose or missing fasteners.

2.2.3.6 Main Rotor Pylon Section Evaluation: Discovery of cracks, excessive wear, or corrosion in this area may require the removal of additional panels to determine the extent of damage (Figure 12).

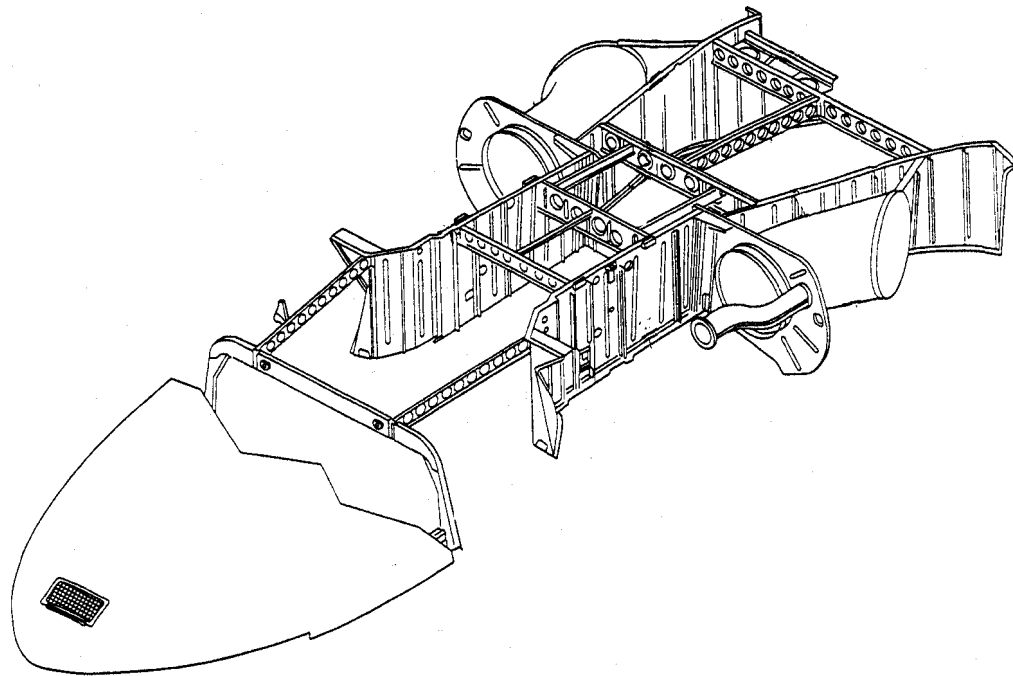

Figure 12. MAIN ROTOR PYLON STRUCTURE

- (a) Frame: Open number 1 and 2 work platforms, and remove/open right and left oil cooler access panels, environmental control system access panel, auxiliary power unit access panel, UHF/IFF antenna cover (if installed), and fire bottle access panel. Examine exposed airframe for cracks, corrosion, excess wear, and loose or missing fasteners.
- (b) Firewall: Examine accessible areas of the for cracks, corrosion, loose or missing fasteners, and condition of seals.
- (c) Oil Cooler Support Bracket: Examine the oil cooler support brackets for cracks, excessive wear, interim repairs, loose or missing fasteners, and corrosion.
- (d) Forward Cover Tracks: Examine the forward cover tracks for excessive wear, cracks, corrosion, and loose or missing fasteners.
- (e) Engine Supports: Inspect the area around the engine supports for cracks and corrosion.

- (f) Main Gearbox Mounting Feet: Closely inspect area around the main gearbox mounting feet for any evidence of corrosion, shifting, loose or missing fasteners, or cracking. The main gearbox should be pulled to allow closer examination of the mounting pads and main transmission support beams if any of these conditions exist.
- (g) Any discrepancies that would require the replacement of a main transmission support beam automatically qualify the aircraft for depot repair.
- (h) Flight Control Deck: Examine the flight control deck and rescue hoist support for evidence of cracks, excessive wear, corrosion, and loose or missing fasteners.
- (i) Exhaust Ejectors: Check the exhaust ejectors and Hover Infrared Suppression System Module (if installed) for cracks, chafing, and loose or missing fasteners. Inspect under the number 1 and 2 inlet ducts for fretting damage to the titanium decking.

2.2.3.7 Main Landing Gear Evaluation

- (a) (Air Force): Remove main landing gear strut access panels. Examine mounting areas of main landing gear for corrosion, cracks, excess wear, and loose or missing fasteners.
- (b) Examine the drag beam attachment fitting for cracks, scratches, dents, and loose fasteners.
- (c) Deleted.

2.2.4 **JACE Condition Codes:** A defect is measured by comparing the normal cross-sectional area of an individual element with the depth and length affected because of scratches, nicks, gouges, holes, dents, or corrosion. Regardless of the type of defect, the amount of material loss is identified as defect reduction. Any defect reduction will affect the strength of the part.

CONDITION	CODE	DEFECT CRITERIA
Worn Excessively	A	Report wear that has proceeded to more than half of the material thickness. For stainless steel wear strips, report wear through.
Buckled	B	Sheetmetal that has been warped, kinked, or deformed by an external force. Creasing due to oil-canning that does not return on its own or that is transmitted into adjoining pockets.
Deteriorated	C	General degradation of non-metals that result in a change of texture, consistency, shape, color, etc., and that reduces the functionality of the item.
Corroded	D	Corrosion of any type that requires repair beyond "Clean and Treat" exceeds minor classification. See Appendix E.
Cracked	E	Cracks of any length exceed minor limits.
Binding	F	Any tight or resistive reaction between two moving surfaces due to deteriorated rollers or bushings or alignment.
Loose Fasteners	G	Any loose fasteners, report the total number of fasteners retaining the fixture or panel followed by the number of loose fasteners in the remarks section of the JACE Checklist.
Missing Fasteners	H	Any missing fasteners, report the total number of fasteners retaining the fixture or panel followed by the number of missing fasteners in the remarks section of the JACE Checklist.
Broken	I	Any break exceeds minor limits.
Punctured	J	Any unauthorized hole is reportable as a puncture.
Chafing	K	Any stationary fixtures or panels rubbing against the other usually identified by a powdery substance around the panel or the fixture edges. Usually the paint or the sealant is worn through.
Oversize Holes	L	Any wear that has caused the holes to enlarge beyond repairable limits.
Security	P	Any condition where an item is not tightly connected to the attaching structure properly.
No Defect	R	If an indicator does not have a defect, circle the R to indicate the indicator was inspected.
Dented	U	Any dent that exceeds 10 percent of thickness or width or length that exceeds 2.5 times the material thickness is a major defect.
Scratched/Nicked	X	Any scratch that exceeds 10 percent of thickness or length exceeds 2.5 times the material thickness is a major defect.
Interim Repair	Y	Interim repair or nonstandard repair not authorized in existing technical data.

3.0 DISTRIBUTION

WR-ALC/LUH Robins AFB GA 31093	(1 Copy)	AMSAT-D-DSL	(2 Copies)
AMSAT-B-DSC	(3 Copies)	AMSAT-B-D-CARP	(10 Copies)
AMSAT-B-DSL	(2 Copies)	AMSAT-I-MED	(50 Copies)
AMSAT-I-MDC	(10 Copies)		

APPENDIX B

JACE Administrative Procedures Form

B-1/(B-2 Blank)

JACE Administrative Procedures

Air Force use AFTO Form 95; Army use DA Form 2408 in the aircraft log book; and Navy use OPNAV 4790/60, Naval Aircraft Flight Records (Yellow sheets, OPNAV 3760/2); and the aircraft log book to complete the following aircraft information:

1. TODAY'S DATE:	2. INSPECTOR CODE:
3. INSPECTION AGENCY:	4. UNIT:
5. LOCATION:	6. AIRCRAFT MODEL:
7. MANUFACTURE YEAR:	8. SERIAL NUMBER:
9. TOTAL HOURS ON AIRCRAFT:	10 AIRCRAFT:NUMBER OF REWORKS
11. COMPREHENSIVE DEPOT REWORKED BY:	
12. AIRCRAFT HOURS AT TIME OF REWORK:	13. DATE OF REWORK:
14. DATE OF LAST AIRCRAFT CONDITION EVALUATION (ACE)/AIRCRAFT SERVICE PERIOD ADJUSTMENT (ASPA) OR JACE:	
15. NUMBER OF PRIOR JACE INSPECTIONS, ACE INSPECTIONS, OR ASPA SEQUENCES:	
16. HOURS AT LAST PHASE:	
17. AIRCRAFT HISTORY: use block 20 for continuation.	
18. LIFE LIMITED STRUCTURAL ITEMS:	
19. OVERALL AIRCRAFT CONDITION:	
20. DISCREPANCY SUMMARY:	

APPENDIX C

Discrepancy Summary Form

C-1/(C-2 Blank)

DISCREPANCY SUMMARY FORM

1. DATE DISCOVERED	2. TIME DISCOVERED	3. UNIT	4. MDS
			5. JCN
6. SERIAL NO.	7. DISCOVERED BY	8. UNIT REPRESENTATIVE	9. LOCATION
10. INDICATOR NOMENCLATURE		11. CORRECTIVE ACTION ESTIMATE (DESCRIPTION OF MAINTENANCE ACTION TO CORRECT THE DEFICIENCY, LEVEL OF MAINTENANCE, MANHOOURS, SPECIAL EQUIPMENT, AND PARTS).	
12. CONDITION/CLASSIFICATION			

The Discrepancy Summary Form is completed for all Major and Critical defects at the time of discovery. Instructions to complete the form are below.

1. **DATE DISCOVERED:** Date of inspection (Day, Month, Year).
2. **TIME DISCOVERED:** Zulu time deficiency discovered.
3. **UNIT:** Unit to which the aircraft is assigned.
4. **MDS:** Model designation of aircraft.
5. **JCN:** Unit job control number.
6. **SERIAL NO:** Serial number of aircraft.
7. **DISCOVERED BY:** inspector's name and code.
8. **UNIT REPRESENTATIVE:** Name and rank of unit representative who witnessed the defect.
9. **LOCATION:** Location of inspection.
10. **INDICATOR NOMENCLATURE:** Defective indicator nomenclature as listed in the JACE Checklist.
11. **CORRECTIVE ACTION ESTIMATE:** Describe the maintenance actions, estimate level of maintenance, estimate the manhours, identify special equipment, and estimate components required to correct the defect.
12. **CONDITION/CLASSIFICATION:** Describe the condition and classify the defect.

APPENDIX D

















































H-60 Joint Airframe Condition Evaluation (JACE) Checklist

D-1/(D-2 Blank)

H-60 JOINT AIRFRAME CONDITION EVALUATION (JACE) CHECKLIST

INDICATOR NOMENCLATURE <small>(PROCEDURES REFERENCE PARAGRAPH)</small>	CONDITION CODE <small>(CIRCLE APPROPRIATE CODE)</small>	DEFECT CLASS <small>(CHECK CORRECT BOX)</small>	REMARKS
NOSE SECTION, TRANSPARENCY FRAMING 2.2.3.1(a)	CEDHGR	<input type="checkbox"/> <input type="checkbox"/> <input checked="" type="checkbox"/>	
NOSE SECTION, EXTERIOR SHEET METAL, F.S. 162-247 2.2.3.1(b)(1)&(2)	EDUBHGYR	<input type="checkbox"/> <input type="checkbox"/> <input checked="" type="checkbox"/>	
COPILOT DOOR FRAMES 2.2.3.1(b)(3)	EDAFJHGYR	<input type="checkbox"/> <input type="checkbox"/> <input checked="" type="checkbox"/>	
COLOR WEATHER RADAR MOUNTS (HH/MH-60A/G/K/L) 2.2.3.1(b)(4)	EDHGCR	<input type="checkbox"/> <input type="checkbox"/> <input checked="" type="checkbox"/>	
FLIR MOUNTS (HH/MH-60A/G/K/L) 2.2.3.1(b)(4)	EDHGCR	<input type="checkbox"/> <input type="checkbox"/> <input checked="" type="checkbox"/>	
COCKPIT FLOOR AND AVIONICS RACKS, NOSE 2.2.3.1(C)(1)&(2)	EDJBHGR	<input type="checkbox"/> <input type="checkbox"/> <input checked="" type="checkbox"/>	
NOSE SECTION FRAME, F.S. 162-247, AND AFT BULKHEAD, F.S. 247, L/H 2.2.3.1(c)(3)	EUDXHGR	<input type="checkbox"/> <input type="checkbox"/> <input checked="" type="checkbox"/>	
AIRFRAME UNDER COPILOT SEAT AND RAILS 2.2.3.1(c)(4)	EUDAPXHGR	<input type="checkbox"/> <input type="checkbox"/> <input checked="" type="checkbox"/>	
INSTRUMENT PANEL SUPPORTS 2.2.3.1(d)	EBHGR	<input type="checkbox"/> <input type="checkbox"/> <input checked="" type="checkbox"/>	
CABIN SECTION, EXTERIOR SHEETMETAL, F.S. 247-379 2.2.3.2(a)	EDUBHGYR	<input type="checkbox"/> <input type="checkbox"/> <input checked="" type="checkbox"/>	
FUEL PROBE MOUNTS (HH/MH-60A/G/K/L) 2.2.3.2(b)	EDHGR	<input type="checkbox"/> <input type="checkbox"/> <input checked="" type="checkbox"/>	
CABIN FRAMES, F.S. 247-295 2.2.3.2(e)(1)	EDABJHGYR	<input type="checkbox"/> <input type="checkbox"/> <input checked="" type="checkbox"/>	
CABIN, GUN SUPPORT BEAMS 2.2.3.2(e)(2)	EDABJHGYR	<input type="checkbox"/> <input type="checkbox"/> <input checked="" type="checkbox"/>	
CABIN FRAMES, F.S. 379 2.2.3.2(e)(3)	EDABJHGYR	<input type="checkbox"/> <input type="checkbox"/> <input checked="" type="checkbox"/>	
CABIN DOOR FRAMES, TRACKS, AND LATCH KEEPS 2.2.3.3(f)(1)&(2)&(3)	EDFHGR	<input type="checkbox"/> <input type="checkbox"/> <input checked="" type="checkbox"/>	
OTHER CABIN INTERIOR STRUCTURE 2.2.3.2(c)&(d)&(g)	EDABJHGY	<input type="checkbox"/> <input type="checkbox"/> <input checked="" type="checkbox"/>	
TRANSMISSION SUPPORT BEAMS 2.2.3.2(h)	ELGHDXR	<input type="checkbox"/> <input type="checkbox"/> <input checked="" type="checkbox"/>	
AIRFRAME AROUND FLIGHT CONTROL/JUNCTION BOX SUPPORT STRUCTURE 2.2.3.2(i)	EDPHGKFR	<input type="checkbox"/> <input type="checkbox"/> <input checked="" type="checkbox"/>	
CABIN FRAMES, F.S. 308 2.2.3.2(j)(2)	EDXUHGR	<input type="checkbox"/> <input type="checkbox"/> <input checked="" type="checkbox"/>	
SERVO BEAM RAILINGS AND T-ANGLE SUPPORTS 2.2.3.2(j)(3)	EDAXHGR	<input type="checkbox"/> <input type="checkbox"/> <input checked="" type="checkbox"/>	
CARGO HOOK SUPPORT FITTINGS 2.2.3.2(j)(4)	EDAXHGR	<input type="checkbox"/> <input type="checkbox"/> <input checked="" type="checkbox"/>	
DELETED		<input type="checkbox"/> <input type="checkbox"/> <input type="checkbox"/>	
DELETED		<input type="checkbox"/> <input type="checkbox"/> <input type="checkbox"/>	
DELETED		<input type="checkbox"/> <input type="checkbox"/> <input type="checkbox"/>	
TRANSITION SECTION, ANTENNA MOUNTS 2.2.3.3(a)	EDPHGCR	<input type="checkbox"/> <input type="checkbox"/> <input checked="" type="checkbox"/>	
TRANSITION SECTION, TAIL ROTOR DRIVE SHAFT SUPPORTS 2.2.3.3(b)	EDHGPR	<input type="checkbox"/> <input type="checkbox"/> <input checked="" type="checkbox"/>	
TRANSITION SECTION, LIFTING EYES SUPPORT STRUCTURE 2.2.3.3(c)	EDHGR	<input type="checkbox"/> <input type="checkbox"/> <input checked="" type="checkbox"/>	
TRANSITION SECTION, EXTERIOR SHEETMETAL 2.2.3.3(d)	EDJBHGYR	<input type="checkbox"/> <input type="checkbox"/> <input checked="" type="checkbox"/>	
TRANSITION SECTION, TORQUE STRIPES, F.S. 485 2.2.3.3(e)	LEDKBYR	<input type="checkbox"/> <input type="checkbox"/> <input checked="" type="checkbox"/>	
TRANSITION SECTIONS INTERIOR, STRINGERS, SHEETMETAL, AND FRAMES 2.2.3.3(f)(1)&(2)	EDHGBYR	<input type="checkbox"/> <input type="checkbox"/> <input checked="" type="checkbox"/>	
DEFECT CLASSIFICATION LEGEND: M=MINOR J=MAJOR C=CRITICAL			

TB 1-1520-237-25-2

TAIL CONE, EXTERIOR SHEETMETAL 2.2.3.4(a)	EDJBHGYR	 	
TAIL CONE, INTERIOR 2.2.3.4(b)(1)&(2)	EBDHGYR	 	
TAIL CONE, ROTOR DRIVESHAFT SUPPORTS 2.2.3.4(c)	EGHD	 	
TAIL CONE BULKHEAD, F.S. 605 2.2.3.4(d)	EUXDR	 	
DELETED.		 	
TAIL CONE< FLIGHT CONTROLS ACCESS PANEL, AND AIRFRAME AROUND THE FLIGHT CONTROL PULLEYS 2.2.3.4(f)	EDHGR	 	
TAIL CONE, CANTED HINGE BULKHEAD, F.S. 647 2.2.3.4(g)&(h)	EDAXUR	 	
TAIL PYLON, EXTERIOR SHEETMETAL 2.2.3.5(a)	EKDBUHGR	 	
TAIL PYLON INTERIOR 2.2.3.5(b)	EDAHGPR	 	
TAIL PYLON HINGE FITTING 2.2.3.5(c)	EDAR	 	
TAIL PYLON, INTERMEDIATE, AND TAIL GEARBOX MOUNTS 2.2.3.5(d)	EDHGCR	 	
TAIL PYLON , STABILATOR AND TAIL SKID 2.2.3.5(e)	EADPHGR	 	
TAIL PYLON, ANTENNA MOUNTS (HH/MH-60A/G/K/L) 2.2.3.5(f)	EKDBUHGCR	 	
PILOT DOOR FRAME 2.2.3.1(B)(3)	EDAFJHGYR	 	
AIRFRAME UNDER PILOT SEAT AND SEAT RAILS 2.2.3.1(c)(4)	EUDAPXHGR	 	
MAIN ROTOR PYLON FRAMES 2.2.3.6(a)	EDAHGR	 	
MAIN ROTOR PYLON FIREWALL 2.2.3.6(b)	EDHGR	 	
OIL COOLER SUPPORT BRACKET 2.2.3.6(c)	EDAHGYR	 	
MAIN ROTOR PYLON, FORWARD COVER TRACKS	EDAHGR	 	
ENGINE MOUNT LUGS AND SUPPORT STRUCTURE 2.2.3.6(e)	EDR	 	
MAIN ROTOR PYLON MAIN GEARBOX MOUNTING FEET 2.2.3.6(F)	DPGHE	 	
FLIGHT CONTROL DECK 2.2.3.6(h)	EDAHGR	 	
EXHAUST EJECTORS 2.2.3.6(i)	EHGKR	 	
MAIN LANDING GEAR/DRAW BEAM ATTACHMENT 2.2.3.7	EDAXUHGR	 	

APPENDIX E
Corrosion Evaluation
(Army and Air Force Only)

**APPENDIX E
CORROSION EVALUATION
(ARMY AND AIR FORCE ONLY)**

1.0 PURPOSE: In order to identify and quantify corrosion trends for preventive or corrective action in the fleet, additional data is required. Data gathering performed in accordance with this Appendix allows detailed reporting of instances of corrosion that might occur over a broad range of airframe and component external surfaces, within the scope of disassembly required for JACE.

2.0 EVALUATION PROCEDURE: The report of an aircraft's corrosion evaluation must remain linked to that aircraft's JACE report. See Table E-1, Corrosion Prevention and Control Evaluation Checklist. While performing the JACE, the evaluator shall inspect for and report corrosion-related information as follows:

2.1 NON-AIRCRAFT ITEM INDICATORS.

2.1.1 Date arrived at current location/previous location/date arrived at previous location. This information is based on entries in the aircraft logbook DA Form 2408-15. Use four digit month/year format for dates. Use city or installation, state, country of location.

2.1.2 Operational environment. More than one may be reported. Narrative may also be used for further description. Indicate the appropriate categories from among the following:

2.1.2.1 MARINE - The aircraft is based and/or operates within a few miles of saltwater.

2.1.2.2 URBAN INDUSTRIAL - The aircraft is usually in an area characterized by regular periods of smog or smoke.

2.1.2.3 NON-COMBAT AWAY - The aircraft is, or has recently been in extended operation away from the maintenance base. Aircraft in field exercise or bailed to another agency are often in this category.

2.1.2.4 RECENT DEPLOYMENT - The aircraft is, or has recently been in combat service.

2.1.2.5 FLOAT - The aircraft has not been flown recently and appears to be a source of parts in controlled substitutions. The length of non-flying time and, if readily available, information relating the cause for float status shall be included in the remarks column.

2.1.3 Local Prevention Program. More than one may be reported. Chapter 3 of tri-service manual NAVAIR 01-1A-509/T.O. 1-1-691/TM 1-1500-344-23 details the features of a corrosion prevention program. One of the most important features is that the activities recur on a scheduled basis. Inquire among the local maintainers on the floor for answers to the following:

2.1.3.1 CORROSION PREVENTION COMPOUND IN USE - These compounds leave an oily or waxy residue where applied, but are not to be confused with the working fluids from power components that may have leaked. Use narrative to report the NSN of the primary corrosion prevention compound in use.

2.1.3.2 ROUTINELY HANGARED - Aircraft is kept inside when not in use and undergoing maintenance.

H-60 Corrosion Prevention and Control Evaluation Checklist									
CPC Indicator Nomenclature	Condition								Remarks
Date Arrived at Current Location (MM/YY)									
Previous Location (Installation or City, State, Country)									
Date Arrived at Previous Location (MM/YY)									
Operational Environment (mark multiple)	Marine	Urban	Industrial	Non-combat	Away	Recent	Deployment		Float
Local Prevention Program (mark multiple)	Corrosion Prevention Compounds Used				Routinely Hangared				<NSN>
Wash Water Quality (mark one)	Untreated	Natural Source	Treated	Natural Source	Municipal	Softened/Rainwater			
Airframe Wash/Preservation Cycle (mark one)	None	Daily	Weekly	Bi-weekly	Monthly	Bi-monthly	Quarterly	Semi-annually	<NSN>
Engine Wash Cycle (mark one)	None	Daily	Weekly	Bi-weekly	Monthly	Bi-monthly	Quarterly	Semi-annually	
	Maintenance Required	Defect Class		Intrusive	Protection	Indirect Indication			
STRUCTURE:									
Any JACE Item With "D" Corroded Reported	T	P	N		See JACE				
CPC--External Stores Support Beams	T	P	N	R	M	J	C		
COMPONENTS:									
CPC--Nose Compartment Electrical/Eletronic	T	P	N	R	M	J	C		
CPC--Instrument Panel/Consoles Electrical/Electronic	T	P	N	R	M	J	C		
CPC--Main and Tail Rotor Servos and SAS Actuators	T	P	N	R	M	J	C		
CPC--Pre-Actuator Flight Controls	T	P	N	R	M	J	C		
CPC--Main Rotor Head	T	P	N	R	M	J	C		
CPC--Main Rotor Blades	T	P	N	R	M	J	C		
CPC--Main Transmission	T	P	N	R	M	J	C		
CPC--Input Modules	T	P	N	R	M	J	C		
CPC--Post-Actuator Flight Controls	T	P	N	R	M	J	C		
CPC--Engines and Engine Sequencing Units	T	P	N	R	M	J	C		
CPC--Oil Cooler	T	P	N	R	M	J	C		
CPC--Auxillary Power Unit and Fuel Control	T	P	N	R	M	J	C		
CPC--Main Rotor Pylon Electical/Electronic	T	P	N	R	M	J	C		
CPC--Misc. Components-Forward Main Rotor Pylon	T	P	N	R	M	J	C		
CPC--Misc. Components-Aft Main Rotor Pylon	T	P	N	R	M	J	C		
CPC--Misc. Components-Cockpit and Cabin Section	T	P	N	R	M	J	C		
CPC--Cabin and Transition Section Electrical/Electronic	T	P	N	R	M	J	C		
CPC--Miscellaneous Components-Transition Section	T	P	N	R	M	J	C		
CPC--Drive Shafts	T	P	N	R	M	J	C		
CPC--Intermediate Gearbox	T	P	N	R	M	J	C		
CPC--Tail Rotor Gearbox	T	P	N	R	M	J	C		
CPC--Tail Rotor Head	T	P	N	R	M	J	C		
CPC--Tail Rotor Blades	T	P	N	R	M	J	C		
CPC--Misc. Components-Tail Boom Empennage	T	P	N	R	M	J	C		
CPC--Miscellaneous Airframe Hardware	T	P	N	R	M	J	C		
CPC--Miscellaneous Components, Other Areas	T	P	N	R	M	J	C		

E-5/(E-6 Blank) Change 1

TB 1-1520-237-25-2

Table E-1 H-60 Corrosion Prevention and Control Evaluation Checklist

2.1.3.3 WASH WATER QUALITY - During in-brief, request that the source of wash water be identified. Natural sources such as lakes, rivers, reservoirs, wells, etc., water from which is not processed by a municipality. Chemical treatments other than softening are referenced by the term "Treated". Softening is a chemical, desalination, or distillation process.

2.1.3.4 AIRFRAME WASH CYCLE - Report from among none, daily, bi-weekly, monthly, bi-monthly, quarterly, or semi-annually, the greatest period that does not exceed the time frame recounted by the local maintainers. Use narrative to report the NSN of the primary cleaner/solvent used for degreasing parts.

2.1.3.5 ENGINE WASH CYCLE - Report from among none, daily, bi-weekly, monthly, bi-monthly, quarterly, or semi-annually, the greatest period that does not exceed the time frame recounted by the local maintainers.

2.2 AIRCRAFT ITEM INDICATORS.

2.2.1 Visually evaluate structure and components for corrosion. Report corrosion conditions found. Corrosion conditions are reported by making entries in the CPC checklist (Table E-1). Entries consist of marking appropriate condition indicators as well as narrative descriptions. While most of the reporting between structures and components is common to both, there are slight variations as follows.

2.2.2 Reporting common to both structures and components:

2.2.2.1 MAINTENANCE REQUIRED - Select one. Codes for completing the column are found in Table E-2, codes for Reporting Maintenance Required.

2.2.2.2 INTRUSIVE - Mark as necessary when it appears the corroded area has progressed out of view into adjoining structure.

2.2.2.3 PROTECTION - Mark as necessary when it appears that a coating, sealant, or gasket failure contributed to the corrosion reported.

2.2.2.4 INDIRECT INDICATION - Mark as necessary when corrosion is indicated indirectly. Indirect indications include color of working fluid in power components such as purple MIL-L-23699, and flakes from scored bearing liners.

2.2.2.5 REMARKS - Use narrative to describe the location and extent of the corrosion. Part numbers, as well as serial numbers, must be reported when corrosion is found on any of the items listed in TB 1-1500-341-01, with the exceptions of the NAV Set Doppler, Improved Data Modem, Inertial Navigation (EGI), and Stabilator Amplifier. Report the time remaining for corroded items listed on time change DA Form 2408-16, of the aircraft logbook. For other items include part numbers if they are readily available via stencil, data plate, etc. Do not spend excessive time searching for a part number. Use fuselage station, waterline, and butt line measurements to the nearest inch or so, when the item is large or otherwise nondescript. Alternately, physical features, such as top, bottom, number of rivets, proximity to lugs, joggles, swagings, etc., may be sufficient to pinpoint locations on some items. Combinations of part number, reference station, and physical features may be necessary to pinpoint location and extent.

Code	Maintenance Required
T	Superficial corrosion requiring "clean and treat only".
P	Corrosion requires fill or patch.
N	Corrosion requires replacement with new item.
R	No defect.

Table E-2 Codes for Reporting Maintenance Required

Code	Defect Class
M	Minor Defect
J	Major Defect
C	Critical Defect
R	No Defect



Table E-3 Codes for Defect Classification

2.2.3 Structures:

2.2.3.1 JACE ITEMS - Whenever the "D" corroded condition is reported in the JACE, additional data is to be recorded in the CPC checklist. Since the "R" no defect condition is no longer an option, it is not included in the CPC checklist. Also it is not necessary to report defect class on the CPC checklist since it is already reported in JACE. JACE items that are found in TB 1-1500-341-01, include Tail Cone Fitting, Tail Pylon Fitting, and Servo Beam Railing.

2.2.3.2 EXTERNAL STORES SUPPORT BEAMS - In addition to the JACE items evaluate the installed external stores support beams, along with attachment struts, as structural components (see paragraph 2.2.4, this appendix). If no defect is found, circle "R" no defect. If the beams are not installed, report nothing to this indicator.

2.2.4 Components. Report the defect class corresponding to either "M" (Minor), "J" (Major), or "C" (Critical), of Appendix A, paragraph 1.6.. Report the "R" no defect condition when no corrosion is found on components. When more than one corroded item is found in the indicator, report coded information against the one that appears to be the greatest driver. Make the first narrative entry in the remarks block correspond to the coded information.

2.2.4.1 NOSE COMPARTMENT ELECTRICAL/ELECTRONIC - Evaluate electronic components and general electronic/electrical hardware including black boxes, isolation mounts, connectors, wiring, terminals, etc.. When corrosion is found, in remarks report available component identifiers as marked on the item.

2.2.4.2 INSTRUMENT PANEL/CONSOLES ELECTRICAL/ELECTRONIC - See paragraph 2.2.4.1. Small white flakes on the dial faces of sealed instruments are an indirect corrosion indication.

2.2.4.3 MAIN AND TAIL ROTOR SERVOS AND SAS ACTUATORS - Items associated with this indicator that are also found in TB 1-1500-341-01 include SAS Actuator, Tail Rotor Pitch CHG SHFT, BRNG T/R Pitch CHG SHFT, Tail Rotor Servo ASSY, and Main Rotor Primary Servo.

2.2.4.4 PRE-ACTUATOR FLIGHT CONTROLS - The majority of these will be found beneath the cockpit floor, in the forward cabin, Main Rotor Pylon, Tailcone, and Tail Pylon. No items associated with this indicator are found in TB 1-1500-341-01.

2.2.4.5 MAIN ROTOR HEAD - Items associated with this indicator that are also found in TB 1-1500-341-01 include Main Rotor Hub, Main Rotor Spindle ASSY, Spindle and Liner ASSY, Spherical Bearing, Main Rotor Spindle Nut, Tie Rod, Control Rod, Control Horn ASSY, and Main Rotor Shaft Extender.

2.2.4.5 MAIN ROTOR BLADES - Items associated with this indicator that are also found in TB 1-1500-341-01 include Main Rotor Blade ASSY, Main Rotor Blade Tip CA, Blade Tip BLK ATTCHG SC, Blade Expandable Pin, M/R Blade Cuff, M/R Blade Cuff (8 Lug), and Main Rotor Blade Cuff (6 Lug). Concentrate your attention on the root and tip portions of the blades.

2.2.4.6 MAIN TRANSMISSION - Items associated with this indicator that are also found in TB 1-1500-341-01 include Main Transmission Module, Swashplate Guide, Dowel Pin, Housing ASSY MGB, and Main Rotor Shaft.

2.2.4.7 INPUT MODULES - Items associated with this indicator that are also found in TB 1-1500-341-01 include Accessory Module and Input Module.

2.2.4.8 POST-ACTUATOR FLIGHT CONTROLS - Items associated with this indicator that are also found in TB 1-1500-341-01 include Swashplate ASSY, Rotating Swashplate, AFT Support Base, AFT Support Strut, AFT Bellcrank SPT ASSY, Lateral Swashplate Link, Lateral Servo Bellcrank, Left Tie Rod ASSY, Right Tie Rod ASSY, R/H Tie Rod ATTCMT Bolt, Forward Bellcrank, and Bellcrank SPT ASSY.

2.2.4.9 ENGINES AND ENGINE SEQUENCING UNIT - Several parts of the engines develop oxidation film that resembles corrosion. These parts will be found with film in all but few engines. Do not report the engines corroded because of the film on these parts. Items associated with this indicator that are also found in TB 1-1500-341-01 include T700-GE-700 Engine ASSY, T700-GE-701C Engine ASSY, and Engine Sequencing Unit.

2.2.4.10 OIL COOLER - Items associated with this indicator that are also found in TB 1-1500-341-01 include Ball Bearing Annular, Fan Axial, and Bearing, Ball.

2.2.4.11 AUXILLARY POWER UNIT - Items associated with this indicator that are also found in TB 1-1500-341-01 include Auxillary Power Unit, APU Fuel Control, and APU Turbine Wheel.

2.2.4.12 MAIN ROTOR PYLON ELECTRICAL/ELECTRONIC - See paragraph 2.2.4.1. Main Rotor Blade Connectors P/J 841, 843, & 844, Droop Stop Heater Connectors P/J 845-848, and internal areas of the SAS Amplifier are corrosion-susceptible. No items associated with this indicator are found in TB 1-1500-341-01.

2.2.4.13 MISCELLANEOUS COMPONENTS - Forward Main Rotor Pylon. This indicator is comprised of the line replaceable units on the upper deck of the Main Rotor Shaft. No items associated with this indicator are in TB 1-1500-341-01.

2.2.4.14 MISCELLANEOUS COMPONENTS - AFT Main Rotor Pylon. This indicator is comprised of the line replaceable units (LRUs) on the upper deck AFT of the Main Rotor Shaft. No items associated with this indicator are in TB 1-1500-341-01.

2.2.4.15 MISCELLANEOUS COMPONENTS - Cockpit and cabin Sections. This indicator consists of LRUs, other than those specifically named, that are attached to the cockpit and cabin sections. No items associated with this indicator are in TB 1-1500-341-01.

2.2.4.16 CABIN AND TRANSITION SECTION ELECTRICAL/ELECTRONIC - See paragraph 2.2.4.1. No items associated with this indicator are in TB 1-1500-341-01.

2.2.4.17 MISCELLANEOUS COMPONENTS - Transition Section. This indicator consists of LRUs, other than those specifically named, that are attached to the Transition Section. No items associated with this indicator are in TB 1-1500-341-01.

2.2.4.18 DRIVE SHAFTS - Items associated with this indicator that are also found in TB 1-1500-341-01 include Driveshaft ASSY Engine; Shaft Assembly, Drive; Shaft Assembly, Fan; Shaft, Rotor, Helicopter; Shaft, Drive, Tail Rotor; and Shaft Assembly, Tail CONT.

2.2.4.19 INTERMEDIATE GEARBOB - Items associated with this indicator that are also listed in TB 1-1500-341-01 include Intermediate Gearbox.

2.2.4.19 INTERMEDIATE GEARBOX - Items associated with this indicator that are also listed in TB 1-1500-341-01 include Intermediate Gearbox.

2.2.4.20 TAIL ROTOR GEARBOX - Items associated with this indicator that can be found in TB 1-1500-341-01 include Tail Rotor Gearbox.

2.2.4.20 TAIL ROTOR HEAD - Items associated with this indicator that are included in TB 1-1500-341-01 include T/R Retention Plate O/B; T/R Retention Plate I/B; and Gearshaft, Bevel.

2.2.4.21 TAIL ROTOR BLADES - Items associated with this indicator that can also be found in TB 1-1500-341-01 include Tail Rotor Blade Assembly.

2.2.4.22 MISCELLANEOUS COMPONENTS - Tail Boom and Empennage. This indicator consists of LRUS attached to the Tail Boom, Vertical Stabilizer, or Stabilator that are not specifically named in another indicator. Items associated with this indicator that are also listed in TB 1-1500-341-01 include Stabilator Actuator and STAB ACT ATTCMT Bolt.

2.2.4.23 MISCELLANEOUS AIRFRAME HARDWARE - Report corrosion to standard hardware, nuts, bolts, rivets, etc. used in sheet metal assembly and the attachment of components that do not move in relation to the airframe. When several instances of hardware corrosion are found, it will be sufficient to report general location and quantities. Report corrosion of fasteners and other hardware used on dynamic or electrical/electronic components to the specific indicator that includes that component.

2.2.4.24 MISCELLANEOUS COMPONENTS - Other areas. Includes components not identified as part of any other indicator.

The following format must be used if submitting an electronic 2028. The subject line must be exactly the same and all fields must be included; however only the following fields are mandatory: 1, 3, 4, 5, 6, 7, 8, 9, 10, 13, 15, 16, 17, and 27.

From: "Whomever" <whomever@avma27.army.mil>

To: 2028@redstone.army.mil

Subject: DA Form 2028

1. **From:** Joe Smith
2. **Unit:** home
3. **Address:** 4300 Park
4. **City:** Hometown
5. **St:** MO
6. **Zip:** 77777
7. **Date Sent:** 19-OCT-93
8. **Pub no:** 55-2840-229-23
9. **Pub Title:** TM
10. **Publication Date:** 04-JUL-85
11. **Change Number:** 7
12. **Submitter Rank:** MSG
13. **Submitter FName:** Joe
14. **Submitter MName:** T
15. **Submitter LName:** Smith
16. **Submitter Phone:** 123-123-1234
17. **Problem:** 1
18. **Page:** 2
19. **Paragraph:** 3
20. **Line:** 4
21. **NSN:** 5
22. **Reference:** 6
23. **Figure:** 7
24. **Table:** 8
25. **Item:** 9
26. **Total:** 123
27. **Text:**

This is the text for the problem below line 27.

RECOMMENDED CHANGES TO EQUIPMENT TECHNICAL PUBLICATIONS

 <div style="border: 1px solid black; border-radius: 15px; padding: 5px; display: inline-block; margin-left: 20px;"> <p style="margin: 0;"><i>THEN...JOT DOWN THE DOPE ABOUT IT ON THIS FORM. CAREFULLY TEAR IT OUT, FOLD IT AND DROP IT IN THE MAIL.</i></p> </div>		SOMETHING WRONG WITH PUBLICATION	
		FROM: (PRINT YOUR UNIT'S COMPLETE ADDRESS)	
		DATE SENT	
PUBLICATION NUMBER		PUBLICATION DATE	PUBLICATION TITLE
IN THIS SPACE, TELL WHAT IS WRONG AND WHAT SHOULD BE DONE ABOUT IT.			
BE EXACT PIN-POINT WHERE IT IS			
PAGE NO.	PARA- GRAPH	FIGURE NO.	TABLE NO.
PRINTED NAME, GRADE OR TITLE AND TELEPHONE NUMBER		SIGN HERE	

The Metric System and Equivalents

Linear Measure

1 centimeter = 10 millimeters = .39 inch
 1 decimeter = 10 centimeters = 3.94 inches
 1 meter = 10 decimeters = 39.37 inches
 1 dekameter = 10 meters = 32.8 feet
 1 hectometer = 10 dekameters = 328.08 feet
 1 kilometer = 10 hectometers = 3,280.8 feet

Weights

1 centigram = 10 milligrams = .15 grain
 1 decigram = 10 centigrams = 1.54 grains
 1 gram = 10 decigrams = .035 ounce
 1 decagram = 10 grams = .35 ounce
 1 hectogram = 10 decagrams = 3.52 ounces
 1 kilogram = 10 hectograms = 2.2 pounds
 1 quintal = 100 kilograms = 220.46 pounds
 1 metric ton = 10 quintals = 1.1 short tons

Liquid Measure

1 centiliter = 10 milliliters = .34 fl. ounce
 1 deciliter = 10 centiliters = 3.38 fl. ounces
 1 liter = 10 deciliters = 33.81 fl. ounces
 1 dekaliter = 10 liters = 2.64 gallons
 1 hectoliter = 10 dekaliters = 26.42 gallons
 1 kiloliter = 10 hectoliters = 264.18 gallons

Square Measure

1 sq. centimeter = 100 sq. millimeters = .155 sq. inch
 1 sq. decimeter = 100 sq. centimeters = 15.5 sq. inches
 1 sq. meter (centare) = 100 sq. decimeters = 10.76 sq. feet
 1 sq. dekameter (are) = 100 sq. meters = 1,076.4 sq. feet
 1 sq. hectometer (hectare) = 100 sq. dekameters = 2.47 acres
 1 sq. kilometer = 100 sq. hectometers = .386 sq. mile

Cubic Measure

1 cu. centimeter = 1000 cu. millimeters = .06 cu. inch
 1 cu. decimeter = 1000 cu. centimeters = 61.02 cu. inches
 1 cu. meter = 1000 cu. decimeters = 35.31 cu. feet

Approximate Conversion Factors

<i>To change</i>	<i>To</i>	<i>Multiply by</i>	<i>To change</i>	<i>To</i>	<i>Multiply by</i>
inches	centimeters	2.540	ounce-inches	Newton-meters	.007062
feet	meters	.305	centimeters	inches	.394
yards	meters	.914	meters	feet	3.280
miles	kilometers	1.609	meters	yards	1.094
square inches	square centimeters	6.451	kilometers	miles	.621
square feet	square meters	.093	square centimeters	square inches	.155
square yards	square meters	.836	square meters	square feet	10.764
square miles	square kilometers	2.590	square meters	square yards	1.196
acres	square hectometers	.405	square kilometers	square miles	.386
cubic feet	cubic meters	.028	square hectometers	acres	2.471
cubic yards	cubic meters	.765	cubic meters	cubic feet	35.315
fluid ounces	milliliters	29.573	cubic meters	cubic yards	1.308
pints	liters	.473	milliliters	fluid ounces	.034
quarts	liters	.946	liters	pints	2.113
gallons	liters	3.785	liters	quarts	1.057
ounces	grams	28.349	liters	gallons	.264
pounds	kilograms	.454	grams	ounces	.035
short tons	metric tons	.907	kilograms	pounds	2.205
pound-feet	Newton-meters	1.356	metric tons	short tons	1.102
pound-inches	Newton-meters	.11296			

Temperature (Exact)

°F	Fahrenheit temperature	5/9 (after subtracting 32)	Celsius temperature	°C
----	------------------------	----------------------------	---------------------	----

